

White-Rodgers Gas Valves

Introduction to Gas Valves

What is a Gas Valve?

A gas valve is an automated valve that controls the pressure of the fuel supplied to the main burner.

The gas valve starts and stops the flow of fuel and controls the pressure the fuel is supplied to the burners.

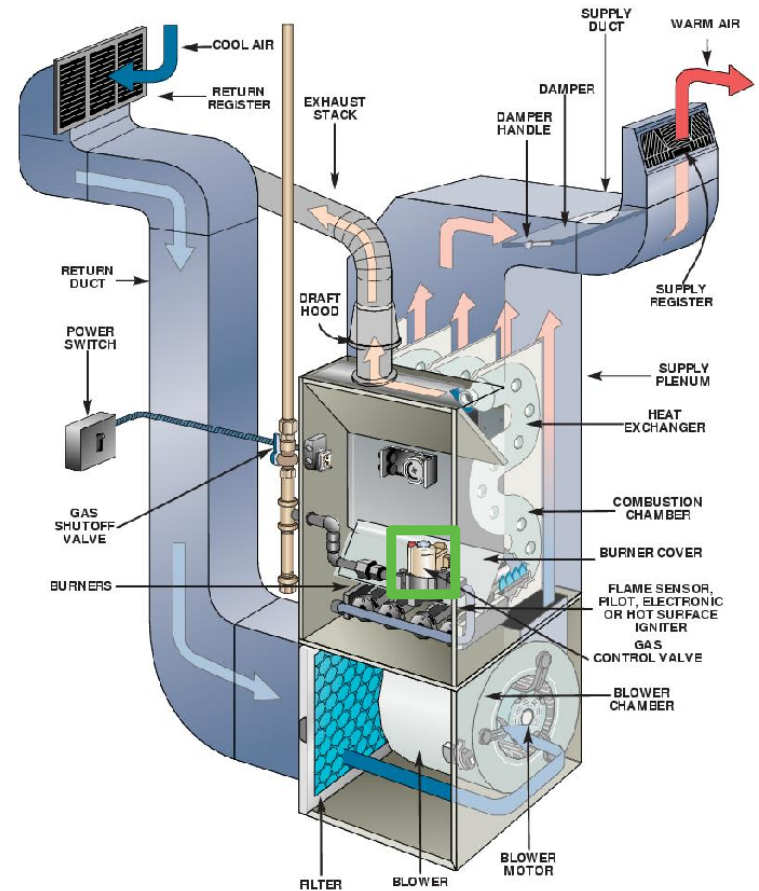
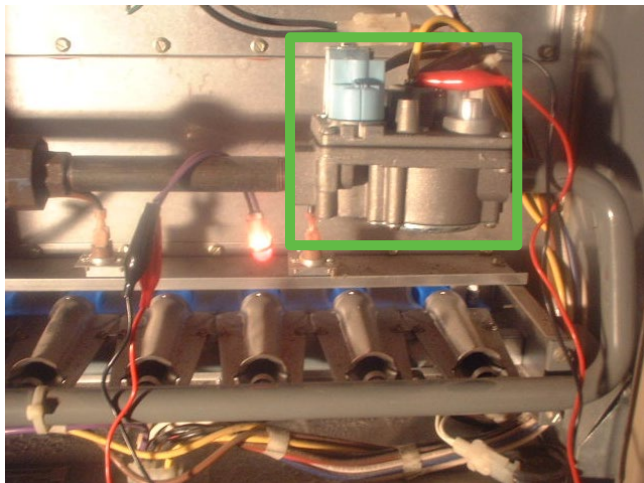

A Basic Gas Train

The modern automatic gas valve combines the previously separate pilot valve, regulator, and solenoid valve.

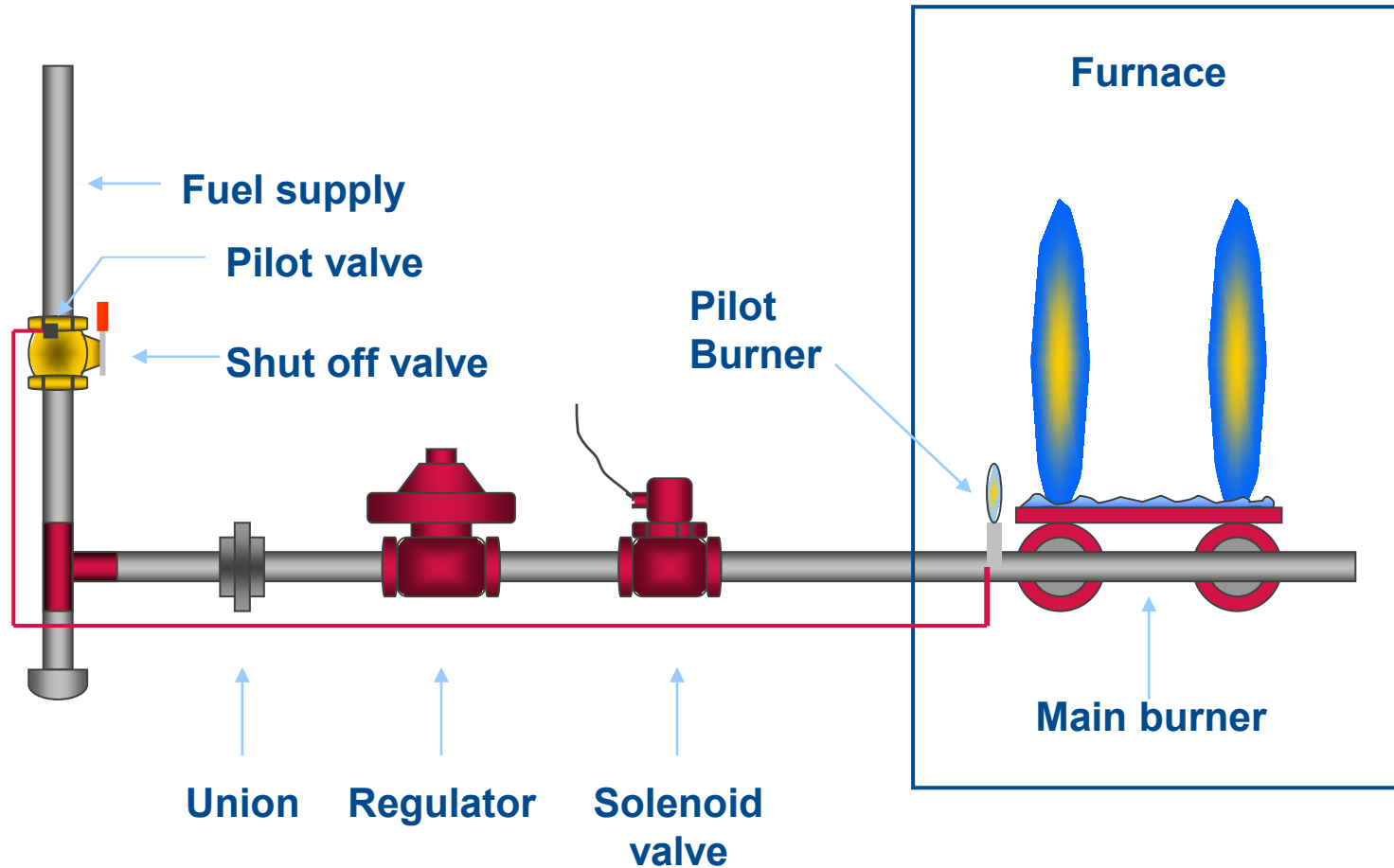

Gas Valve Main Components

1. Valve solenoid
2. Pressure tap inlet
3. Redundant valve
4. Main valve
5. Supply inlet
6. Diaphragm
7. Regulator valve
8. Main burner outlet
9. Regulator adjustment spring
10. Regulator adjust screw
11. Pressure tap outlet

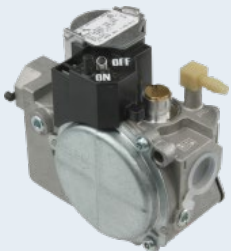
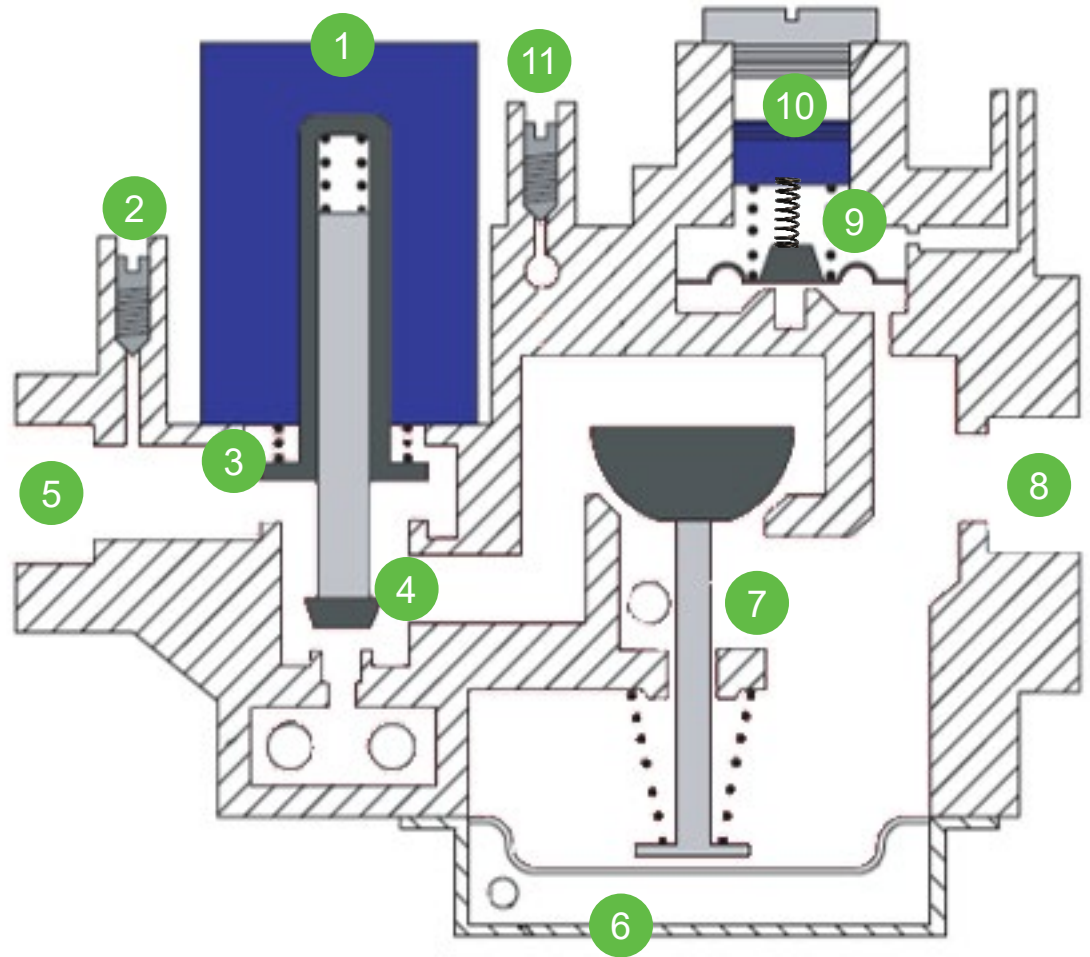

**36J Series
Gas Valve**

Gas Valve Operation

Normal operation with no voltage applied to solenoid.

1. Redundant valve closed
2. Main valve closed
3. Continuous inlet pressure from supply line
4. Regulator valve will not open without pressure applied

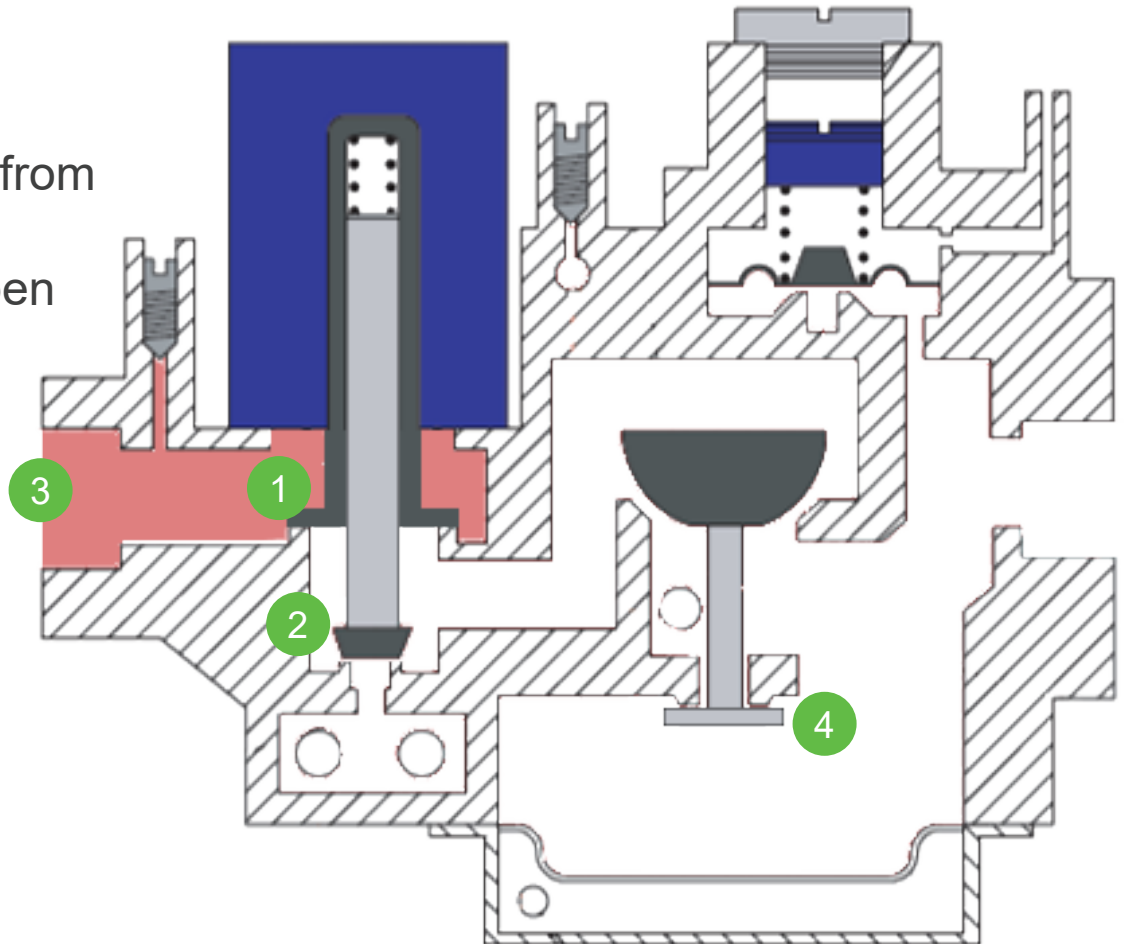

Gas Valve Operation

When the solenoid is energized, the redundant and main valves open.

1. Continuous inlet pressure from supply line
2. An internal channel connecting the control gas orifice to the opening orifice allows pressurized gas into the back side of diaphragm, forcing the regulator valve open
3. Pressurized gas also passes internally to the adjustable regulator, where it supplies back-pressure on the main diaphragm, only allowing it to open to set pressure
4. Outlet pressure to manifold

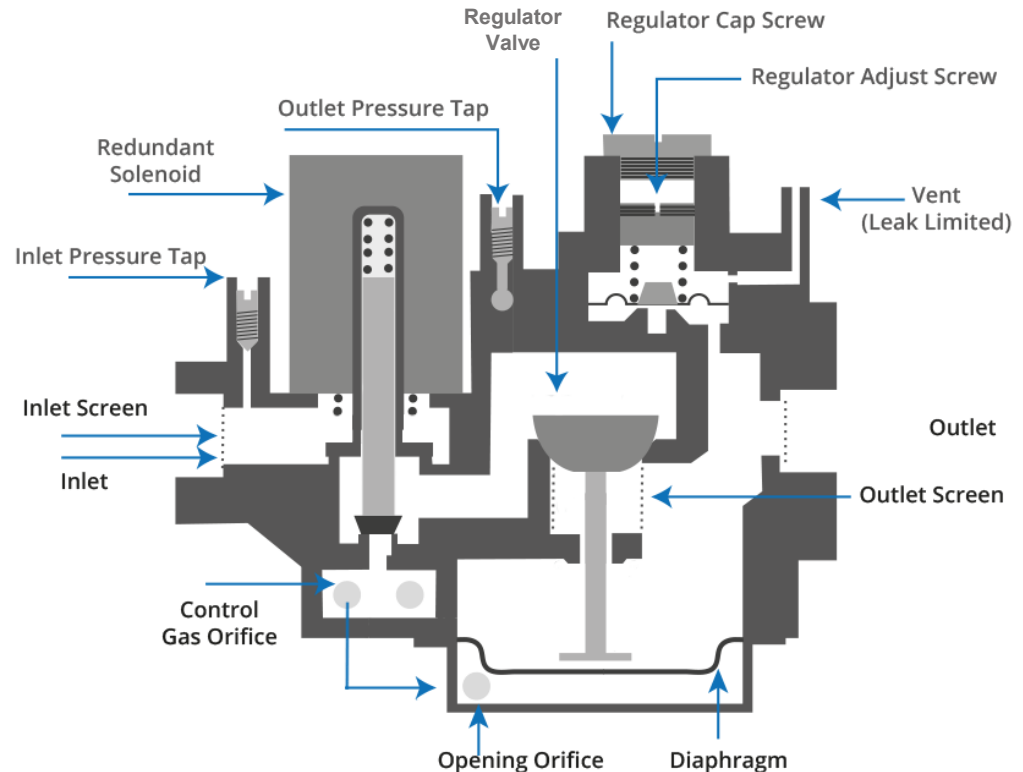

Gas Valve Operation

Pressure on back side of adjustable regulator diaphragm must be vented.

1. Continuous inlet pressure from supply line
2. Outlet pressure to manifold
3. Regulator vent

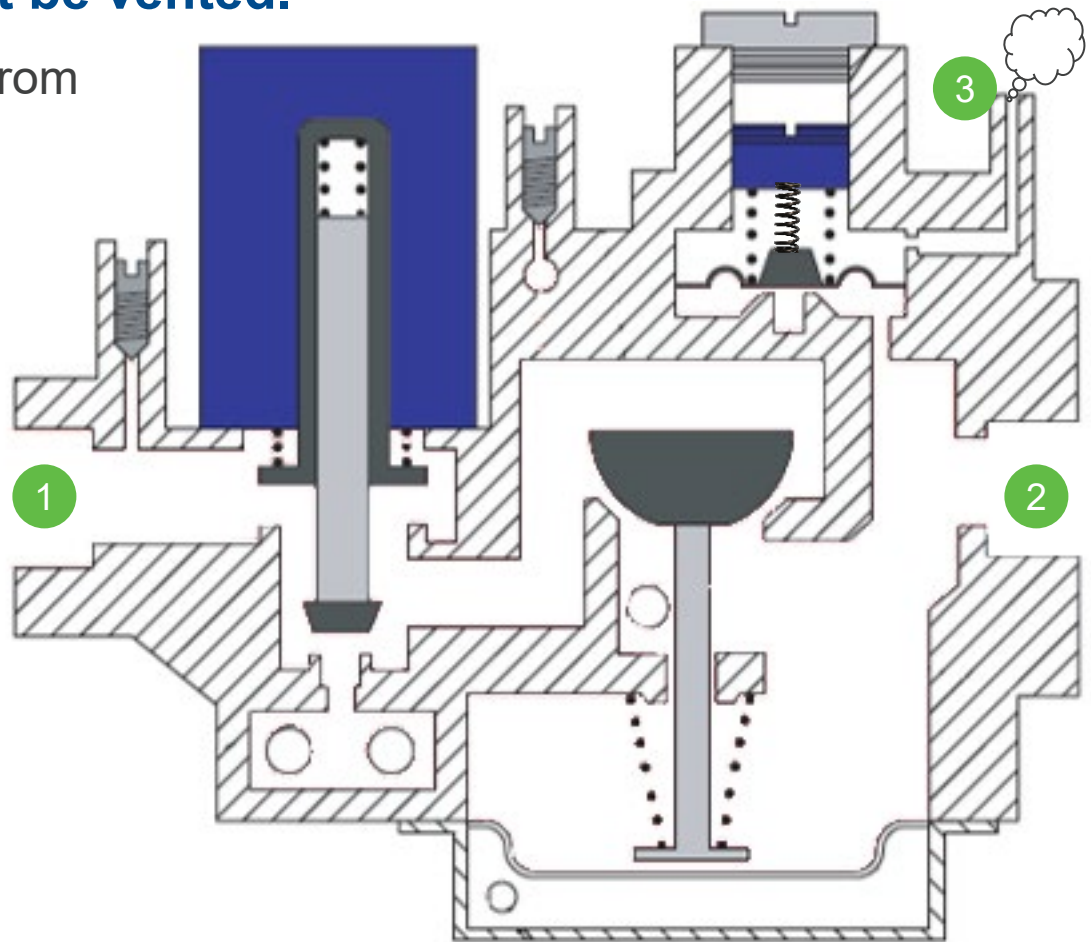

**36J Series
Gas Valve**

Standard (Fast) and Slow Open Curve

A standard open gas valve will immediately go to full pressure and hold. A slow open gas valve will take 8 seconds to ramp to full pressure.

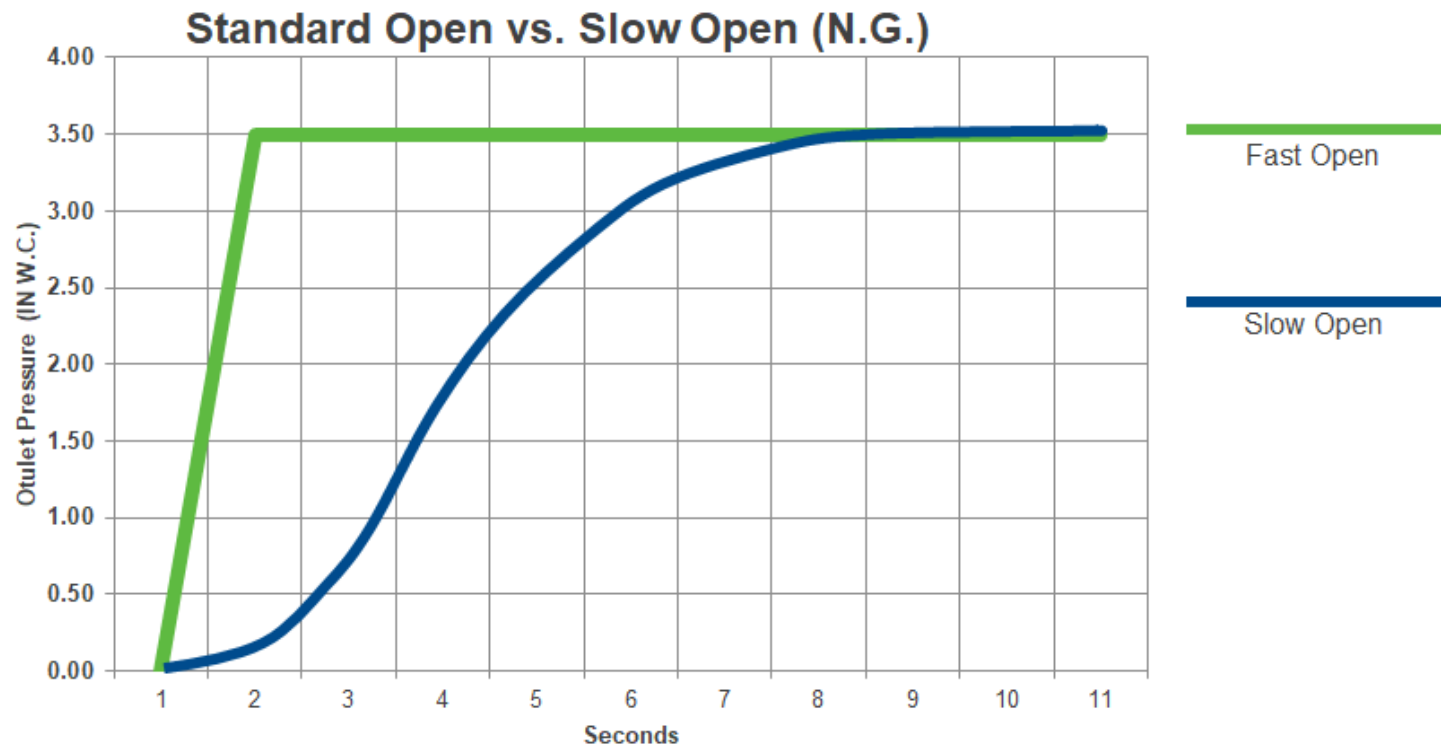

TECH TIP: Slow opening gas valves provide a gradual increase in outlet pressure for a smoother ignition.

Key Takeaways

- Gas valves automatically control the pressure of the fuel supplied to the burners
- A modern automatic gas valve contains a solenoid valve, a pressure regulator, and if needed, a pilot valve
- Gas valves are often classified by the amount of time they take to fully open
- The regulator portion of a gas valve must be vented for proper operation

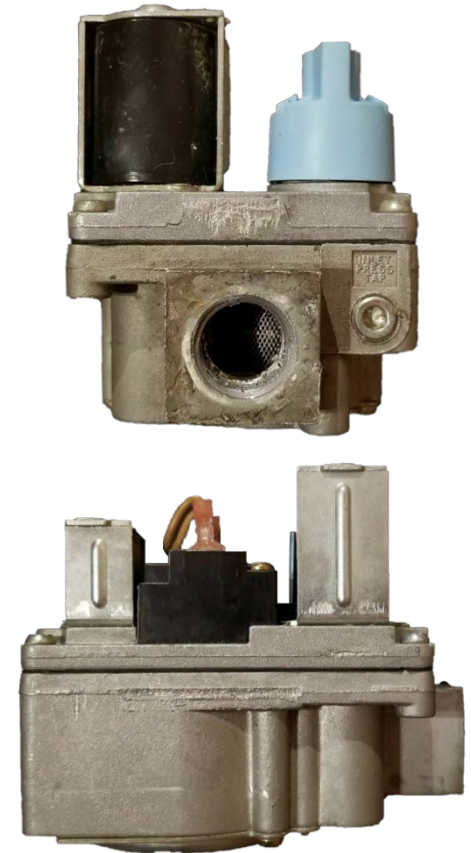

Selecting a Correct Replacement Gas Valve

Gas Valve Classification

Gas valves are classified by:

1. Ignition source

- Standing/cycle pilot
- Proven/intermittent pilot
- Direct burner
 - Hot surface ignition (HSI)
 - Direct spark ignition (DSI)

2. BTU input and output

- Capacity is found on the rating plate

3. Opening characteristics

- Fast open
- Slow open
- Step open
- Two-stage

MFD. FOR
PREMIER FURN
P. O. BOX 78
LAFAYETTE, LA

What is this?

GAS INPUT		OUTLET AIR		STATIC PRESSURE		
75,000 BTU/HR		TEMP 155 °F		0.50 "WC		
TYPE GAS	MANIFOLD PRESSURE	MAX. GAS SUPPLY PRESS.	MIN. GAS SUPPLY PRESS.	ORIFICE SIZE		
NAT	3.5 "WC	7.0 "WC	4.5 "WC	41 DMS		
AIR TEMP RISE	LIMIT SETTING	BLOWER SIZE	MOTOR HP	POWER USAGE	MAX AMPS	ELECTRICAL POWER SUPPLY
25-55 °F	220 °F	10-8	1/3	520 W	6.4	115V, 1PH, 60HZ
MAX. COOLING AIR FLOW NOT AGA CERTIFIED			ONLY QUALIFIED SERVICE PERSONNEL SHOULD SERVICE THIS EQUIPMENT			WHEN ORDERING PARTS REFER TO MOD. & SER. NOS
1617 CFM @ 0.50"WC						
MOD. NO. HACO/5NF4RXL				PT. NO. 5745188100		
SER. NO. 850304091				P.O.A-0261		
D.C. EA85/E8506/H8441/E8503/P285/E8502						

207049

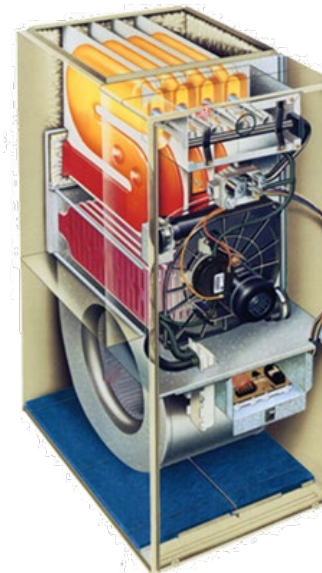

Classification by Ignition Source

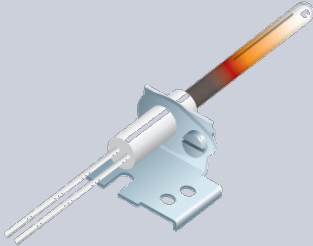
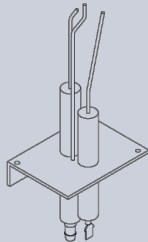
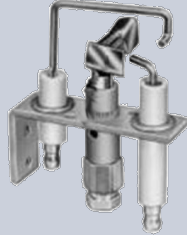
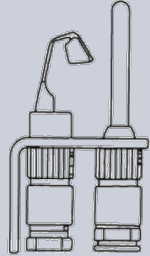
	Direct Burner Ignition		Proven / Intermittent Pilot	Standing / Continuous Pilot
	Hot Surface Ignition (HSI)	Direct Spark Ignition (DSI)		
W-R Valve	36J, 36H, or 36G	36J, 36H, or 36G	36H or 36G	36C
Ignition Source				
	Resistive element that heats up to light the gas with direct or indirect flame sensor	Ground electrode, with spark electrode flame sensor	Pilot burner to ground, with a spark electrode and flame sensor	A traditional pilot burner with a thermocouple - no spark electrode or flame sensor
Usage	Majority of current furnaces	Selected applications	Mostly packaged unit applications	No longer used in OEM production for residential HVAC

Classification by Rated Valve Capacity - BTUs

- Pressure drop
 - Valves are rated at 1" W.C. of pressure between inlet and outlet readings in the fully open position
 - Range of regulation determines minimum/maximum flow capacity range
- Reducing bushing
 - Connector sizing determines cubic feet per hour and overall capacity

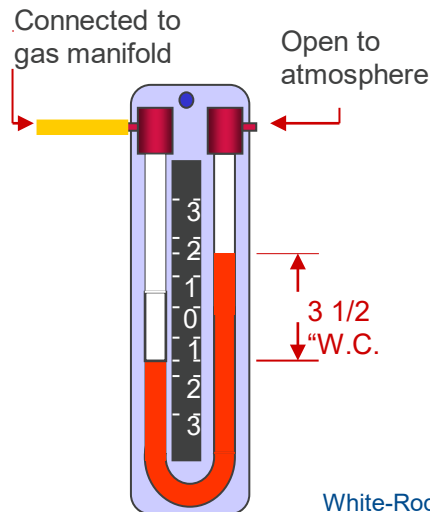
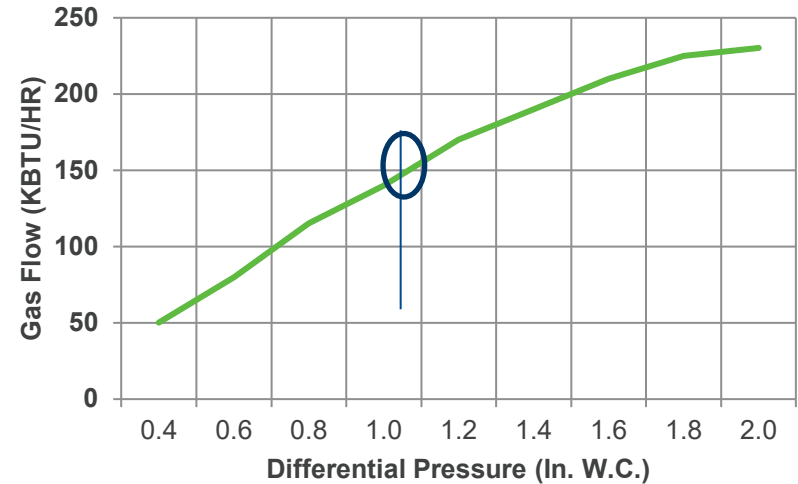

1" Pressure Drop With Bushings		
36C Valve	N.G.	L.P.
1/2 x 1/2	230,000	372,600
1/2 x 3/4	230,000	372,600
3/4 x 3/4	280,000	453,600

Classification by Opening Characteristics

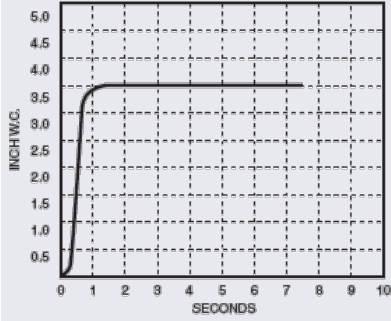
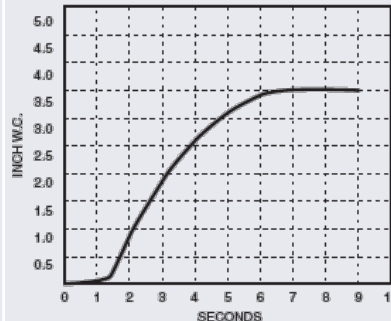
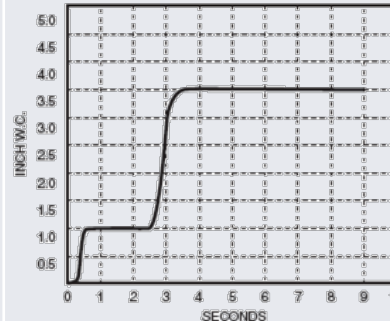
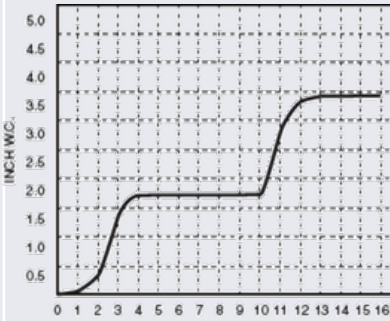
Fast Open	Slow Open	2-Stg Fast Open	2-Stg Slow Open
36J22, 36H32 36G32, 36C03	36J24 36H33 36G33	36J54 36H64	36J55 36H65
			
<p style="text-align: center;"><u>Fast Open</u></p> Fast rise to full outlet pressure upon energizing the valve	<p style="text-align: center;"><u>Slow Open</u></p> Slow increase of gas to full outlet pressure for smoother ignition	<p style="text-align: center;"><u>Two-Stage Open</u></p> Low pressure 1 st stage (low fire) and then full outlet pressure on a call for 2 nd stage heat Can be fast or slow open on both stages	

Verify specific model numbers before replacing any control.

Selecting a Gas Valve

- The following slides break down potential White-Rodgers gas valve options, with a variety of applications.
- Selection can be broken down in all cases by application, ignition source, BTU rating, and opening characteristics.
- When in doubt, WR Mobile is a great resource for easily searching existing WR and competitive products for the best replacement.

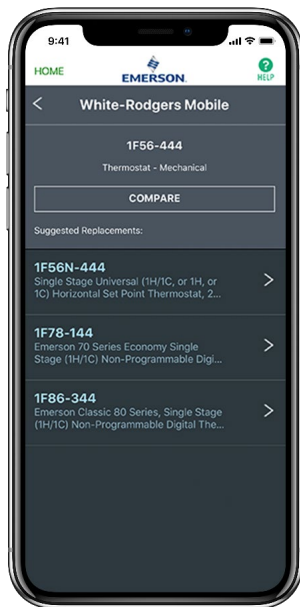

WR Mobile

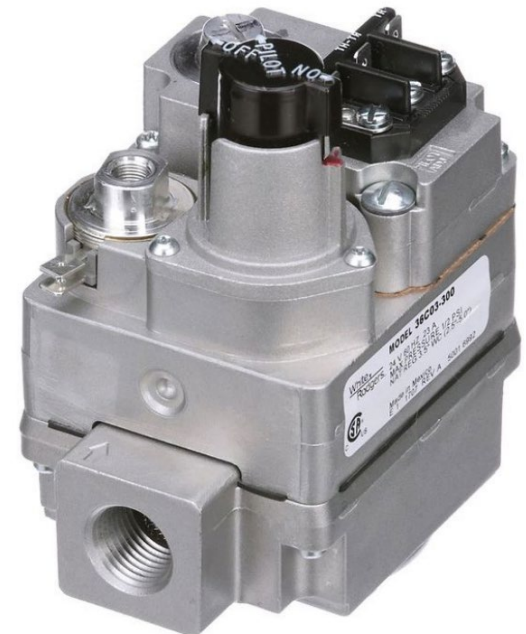

White-Rodgers Gas Valves

25M Gas Valves



25M Gas Valve

Clothes dryer gas valves combine pressure regulator main and redundant solenoids for hot surface ignition dryers.

- Compact split coil design
- Inlet/outlet screen
- Field-adjustable regulator
- Replaceable operating coils (no gas interruption)
- Outlet pressure tap
- Both models packaged with the most popular main burner orifices to replace many OEM models
- Replacement coils available for most popular models
- Single or complete coil sets

COIL VOLTAGE	OUTLET FLOW DIRECTION	INLET/OUTLET SIZE	REGULATOR ADJUSTMENT RANGE	MOUNTING	MODEL NUMBER	ITEM NUMBER
120 VAC	Right Angle Left	3/8" NPT X 11/32"	Nat. Gas: 2.8" to 5.4"W.C. LP Gas: 8.5" to 12.0"W.C. (Conversion Kit Included)	Control may be mounted in the following positions: horizontal, vertical or 90° of horizontal. Do not mount upside down.	25M01A-100	25M01A100
120 VAC	Right Angle Right	3/8" NPT X 11/32"	Nat. Gas: 2.8" to 5.4"W.C. LP Gas: 8.5" to 12.0"W.C. (Conversion Kit Included)	Control may be mounted in the following positions: horizontal, vertical or 90° of horizontal. Do not mount upside down.	25M01A-101	25M01A101

25M Gas Valves

1. Appliance type: **Dryer**
2. Ignition type: **HSI/DSI**
3. Control voltage: **120VAC**
4. Opening style: **Fast**
5. Staging: **Single**
6. Appliance input Btu/H: **See table**

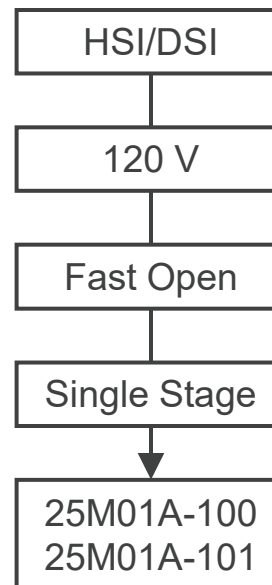

764 Gas Valves



764 Gas Valve

Thermocouple operated control with 100% shut off.

- Manual on-off knob and thermocouple operated pilot safety
- Inlet screen and inlet pipe stop
- Mounts in any position including upside down

VOLTAGE	PIPE SIZE	FLOW DIRECTION	1" PRESSURE DROP CAPACITY NATURAL GAS .64 SP. GR. (1000 BTU/FT ³)	1" PRESSURE DROP CAPACITY LP GAS 1.53 SP. GR. (2500 BTU/FT ³)	MODEL NUMBER	ITEM NUMBER
20 to 30 mV Thermocouple	1/2" X 1/2"	Str. Thru	124,000	200,880	764-501	764-501
20 to 30 mV Thermocouple	1/2" X 1/2"	*Dual Inlet Str. Thru with Optional Bottom Inlet	Side Inlet 124,000, Bottom Inlet 118,000	Side Inlet 200,880, Bottom Inlet 191,160	764-742	07 64 742S1

764 Gas Valves

1. Appliance type: **Fireplace**
2. Ignition type: **Standing Pilot**
3. Control voltage: **20-30 mV**
4. Appliance input Btu/H

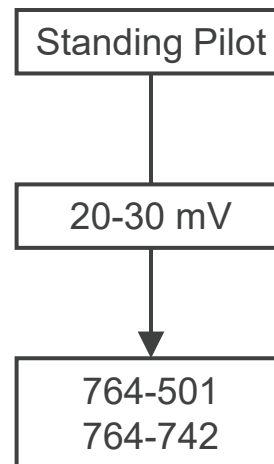

36C Gas Valve Family



36C Gas Valve

Universal replacements for Standing Pilot systems

- Line interrupter styles use standard 30 mV thermocouples
- Straight through design with side tapped models available
- Inlet / outlet reducer bushings included on select models
- Mounting position upright, or 0° to 90° from upright in any direction

Ideal general purpose replacements for Cycle-Pilot Intermittent Ignition (IID) systems

- Straight through design
- Mounting position upright, or 0° to 90° from upright in any direction
- Inlet/outlet reducer bushings

PIPE SIZE	1" PRESSURE DROP CAPACITY NATURAL GAS .64 SP. GR. (1000 BTU/FT ³)	1" PRESSURE DROP CAPACITY LP GAS 1.53 SP. GR. (2500 BTU/FT ³)	RANGE OF REGULATION NATURAL GAS .64 SP. GR. (1000 BTU/FT ³)	RANGE OF REGULATION LP GAS 1.53 SP. GR. (2500 BTU/FT ³)
1/2" X 3/8"	100,000	162,000	15,000-100,000	15,000-162,000
1/2" X 1/2"	230,000	372,600	30,000-290,000	30,000-469,000
1/2" X 3/4"	230,000	372,600	30,000-290,000	30,000-469,000
3/4" X 3/4"	280,000	453,600	50,000-400,000	50,000-648,000

36C Family Gas Valve Selector

1. Typical Application: **Furnace/Boiler**
2. Ignition type: **Standing Pilot/Cycle Pilot**
3. Control voltage: **750mV/24/120VAC**
4. Opening style: **Fast/Slow**
5. Staging: **Single Stage**
6. Pipe size/Appliance input Btu/H: **See table**

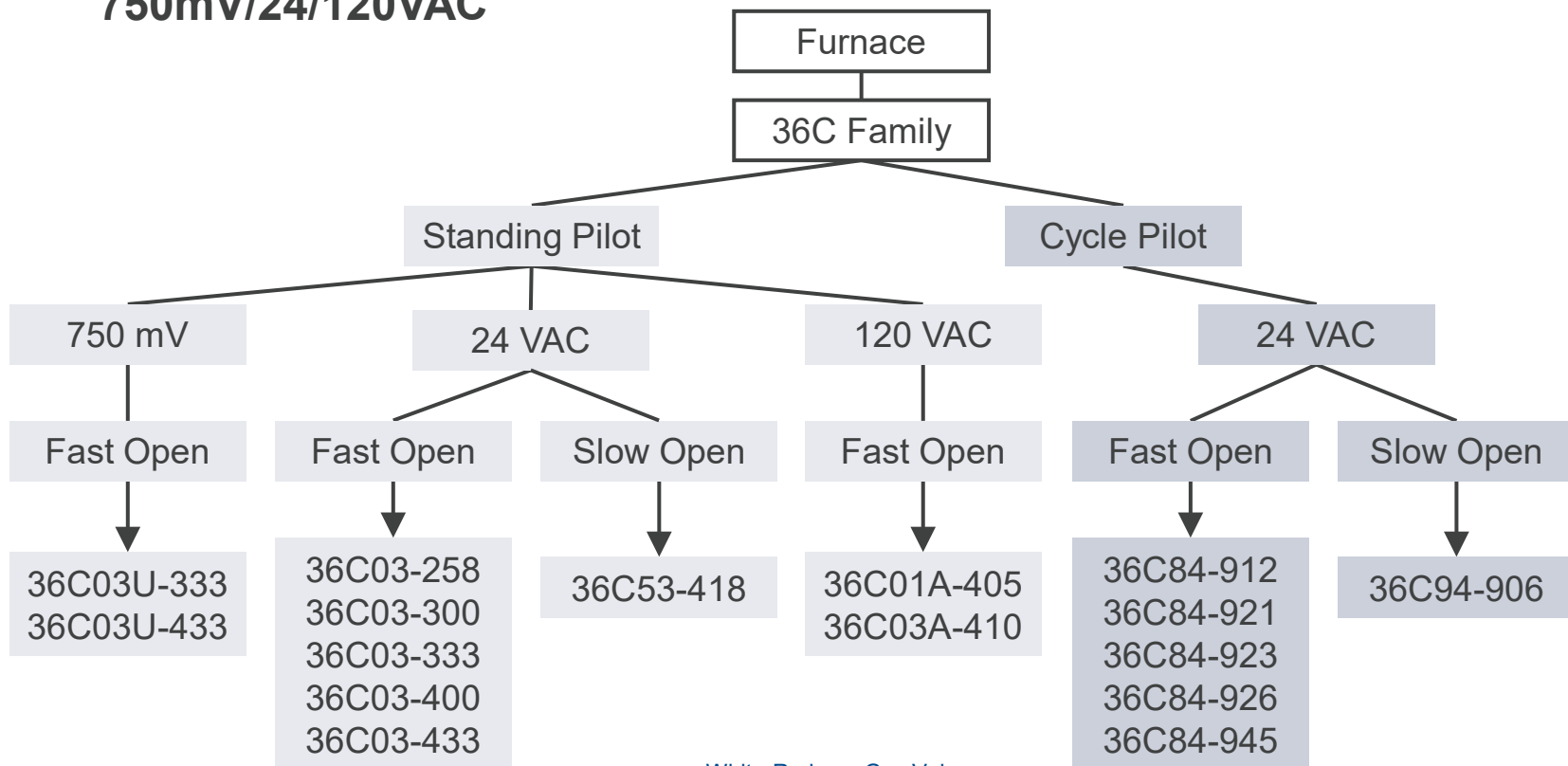

36H Gas Valve Family



36H Gas Valve

Universal electronic ignition gas valves. Our highest capacity multi-function combination control covering a wide range of gas heating applications.

- Pilot port plugged for Hot Surface and Direct Spark Ignition systems, remove plug for Intermittent / Proven Pilot systems
- Fast open, slow open, single and two stage models
- Electric on-off switch and convenient quick connect coil terminals
- Tamper resistant screws and controlled gasket compression to withstand high inlet pressures
- Mounting position upright, or 0° to 90° from upright in any direction
- Dimensions: 4"L x 3"W x 5"H

PIPE SIZE	1" PRESSURE DROP CAPACITY NATURAL GAS .64 SP. GR. (1000 BTU/FT ³)	1" PRESSURE DROP CAPACITY LP GAS 1.53 SP. GR. (2500 BTU/FT ³)	RANGE OF REGULATION NATURAL GAS .64 SP. GR. (1000 BTU/FT ³)	RANGE OF REGULATION LP GAS 1.53 SP. GR. (2500 BTU/FT ³)
3/4" x 3/4"	300,000	486,000	50,000-400,000	81,000-648,000
1/2" x 3/4"	230,000	372,600	50,000-300,000	80,000-500,000
1/2" x 1/2"	170,000	275,500	40,000-240,000	40,000-400,000

36H Family Gas Valve Selector

1. Typical Application: **Furnace/Boiler**
2. Ignition type: **Intermittent/Proven Pilot/HSI/DSI**
3. Control voltage: **24VAC**
4. Opening style: **Fast/Slow**
5. Staging: **Single/Two Stage**
6. Pipe size/Appliance input Btu/H: **See table**

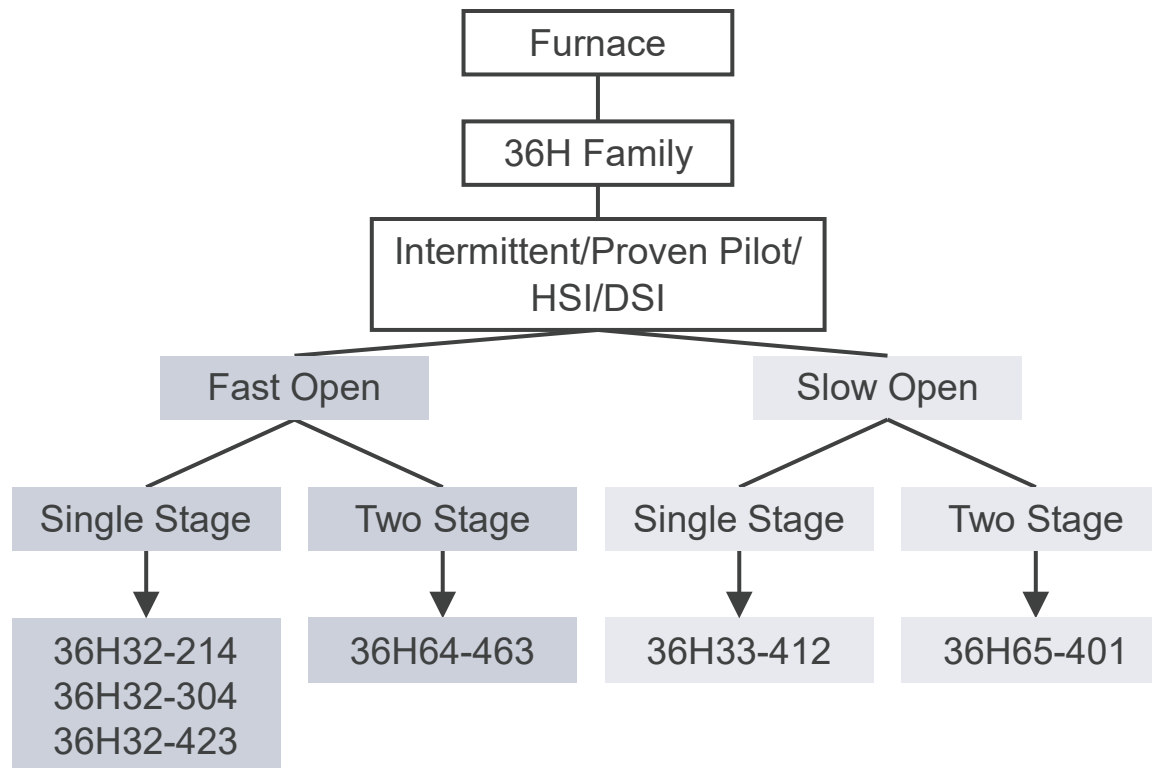

36G/J Gas Valve Family



36H Gas Valve

Designed for use with common ignition systems (HSI/DSI/ Intermittent/Proven Pilot). This series is our most compact footprint combination gas valve.

- Designed for hot surface, direct spark and intermittent pilot ignition systems and features a compact footprint and versatile range
- Fast open, slow open, single and two stage models
- Electric on-off switch and convenient quick connect coil terminals and built-in pressure taps
- Tamper resistant screws and controlled gasket compression to withstand high inlet pressures
- Mounts in any position including upside down
- Dimensions: 3 ¾”L x 2 ½”W x 4 ¼”H

VALVE (STAGES)	PIPE SIZE	1" PRESSURE DROP CAPACITY NATURAL GAS .64 SP. GR. (1000 BTU/FT ³)	1" PRESSURE DROP CAPACITY LP GAS 1.53 SP. GR. (2500 BTU/FT ³)	RANGE OF REGULATION NATURAL GAS.64 SP. GR. (1000 BTU/FT ³)	RANGE OF REGULATION LP GAS 1.53 SP. GR. (2500 BTU/FT ³)
Single	1/2" x 1/2"	140,000	226,800	40,000-210,000	60,000-340,000
Two	1/2" x 1/2"	140,000	226,800	20,000 Low-210,000 High	32,000 Low-340,000 High
Modulating	1/2" x 1/2"	140,000	226,800	20,000-210,000	32,600-340,000

36G/J Family Gas Valve Selector

1. Typical Application: **Furnace/Boiler**
2. Ignition type: **Intermittent/Proven Pilot/HSI/DSI**
3. Control voltage: **24VAC**
4. Opening style: **Fast/Slow/Modulating**
5. Staging: **Single/Two Stage**
6. Pipe size/Appliance input: **Btu/H**

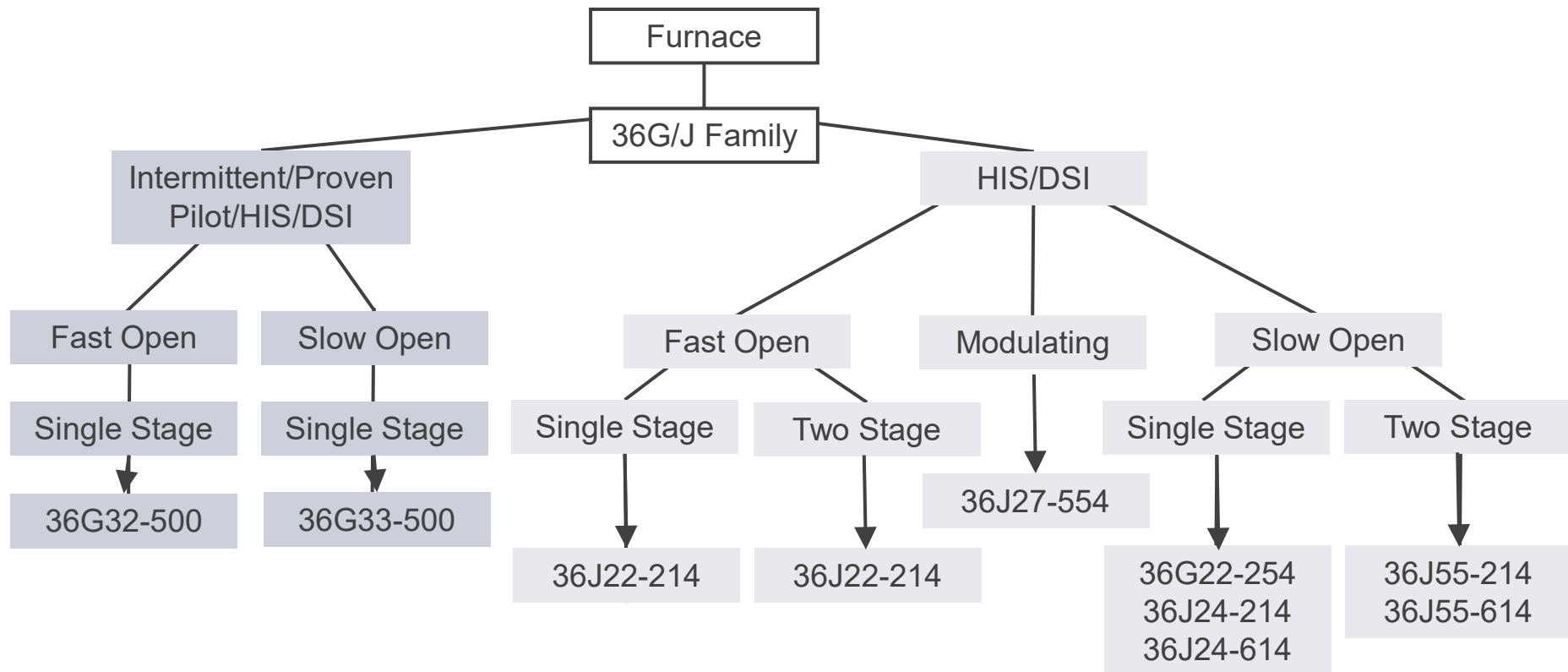

Universal Valves to Keep on Hand

Model Number	Ignition Source	N.G. Range x 1,000Btu	L.P. Range x 1,000Btu	Pipe Size	Opening Curve	Stages	% of OEM Usage
36J22-214	Direct Burner Ignition (HSI / DSI)	40-210	60-340	½ x ½	Fast	1	28%
36J24-214*					Slow	1	47%
36J54-214		20 Low-210 High	32 Low-340 High		Fast	2	25%
36J55-214*					Slow	2	
* 36J valve is offered in a -614 Version that gives you a 90° Bottom Outlet—Primarily used in Carrier Furnaces							
36H32-304	Direct Burner Ignition or Proven Pilot	50-300	80-500	½ x ¾	Fast	1	69%
36H32-423		50-400	81-648	¾ x ¾	Fast	1	
36H33-412					Slow	1	12%
36H64-463					Fast	2	19%
36H65-401					Slow	2	
36G32-500		40-210	60-340	½ x ½	Fast	1	Replacement Only
36G33-500	Slow				1		
36C03-300	Standing Pilot	30-290	30-469	½ x ¾	Fast	1	Replacement Only
36C03-433		50-400	50-648	¾ x ¾	Fast	1	

Choosing the Correct Replacement Valve

More information can be located by referencing the defective valve part number

- On the box
- Visor card
- WR Mobile
- Catalog

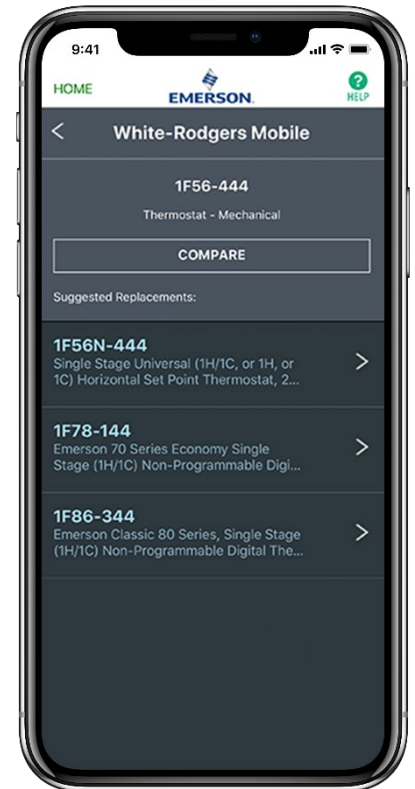

36J22-214

Replacement Gas Valve Robinet de gaz de remplacement

Full On-Line Cross Reference Guide de référence complet en ligne



36J22-214 replaces the following models / remplace les modèles suivants

025-38979-000	36E16-204	36G22-213	36G29-202	C341950P01
11J28-06892-001	36E32-201	36G22-214	36J22-208	D673493P01
120-09319	36E36-284	36G22-223	36J22-209	EF32CW031
12908	36F22-202	36G22-510	36J22-223	EF32CW035
20466803	36F22-213	36G22-512	36J22-257	X13120655010
3004-1301	36G22-208	36G22Y-202	5H0797510000	X13120672010

Features

- 1/2" x 1/2" Inlet/Outlet
- Convertible - Natural or LP Gas (LP conversion kit included)
- Reducer Bushing Kit included: 2 pieces - 1/2" x 3/8"

Specifications

Pressure Regulator Adjust Range

Natural Gas: 2.5" to 5.0" W.C.
LP Gas: 7.0" to 12.0" W.C.

Voltage: 24 VAC, 50/60 Hz

Pressure Regulator Setting: 3.5" W.C.

Capacity at 1" PD: 140,000 BTU/HR

Se incluyen instrucciones en español

Caractéristiques

- Entrée/sortie 1/2 po sur 1/2 po
- Convertible – gaz naturel ou GPL (trousse de conversion au GPL comprise)
- Trousse de raccord de réduction comprise : 2 pièces – 1/2 po sur 3/8 po

Spécifications

Planche de réglage du régulateur de pression

Gaz naturel : 2,5 po à 5,0 po W.C.
GPL : 7,0 po à 12,0 po W.C.

Tension: 24 V c.a., 50/60 Hz

Réglage du régulateur de pression: 3,5 po W.C.

Capacité à 1 po PD: 140 000 BTU/HR

Box

Furnace Controls Cross-Reference

Gas Valves

White-Rodgers

PART #	DESCRIPTION	REPLACES	DESCRIPTION	REPLACES	DESCRIPTION	REPLACES	DESCRIPTION	REPLACES	DESCRIPTION	REPLACES
1000000000	VALVE	1000000000	VALVE	1000000000	VALVE	1000000000	VALVE	1000000000	VALVE	1000000000

Cross Reference

Key Takeaways

- The proper replacement gas valve must meet the following requirements
 - Ignition source
 - BTU input and output
 - Opening characteristics
- Additional information can be found using the White Rodgers Mobile app

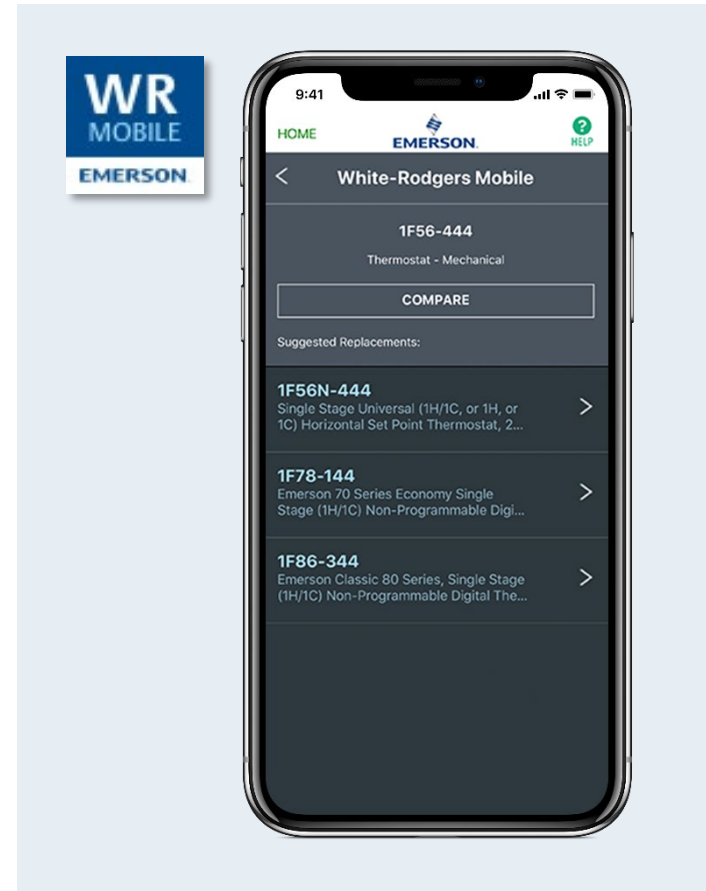

WR Mobile App

Always up-to-date and easy to use:

- Mobile App
- White-Rodgers Website



Your resource for:

- Product information and spec sheets
- Complete Cross Reference
- OEM compatibility
- Installation information and videos
- Wiring diagrams

Download:

- Go to your app store
- Type in **WR Mobile**
- Install the app



OR

- Open your camera
- Hold it over the QR code
- Tap “Open” on the pop-down
- Install the app



Installing Gas Valves

Best Practices

- Do not short out terminals on gas valve or primary control to test.
 - Short or incorrect wiring can cause equipment damage, property damage, and/or personal injury.
- This control is not intended for use in locations where it may come in direct contact with water.
 - Suitable protection must be provided to shield the control from exposure to water (dripping, spraying, rain, etc.).
- Clean gas piping of contaminants, cutting fluid, or other chemicals which might react harmfully with the gas valve components before install.
- When performing service or maintenance on equipment, visually inspect the equipment for code violations and safety hazards and inform the equipment owner of the need for repair.

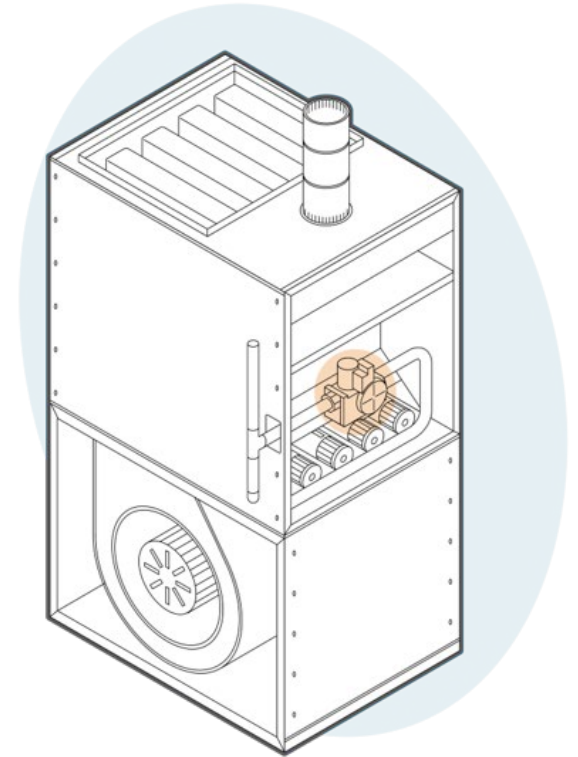

Gas Valve Replacement

Turn off the power and gas to the furnace and remove the access panels.



Removing the Old Valve from the Manifold

If the equipment does not accommodate the swing radius of the gas valve, the manifold may be removed from the burners.

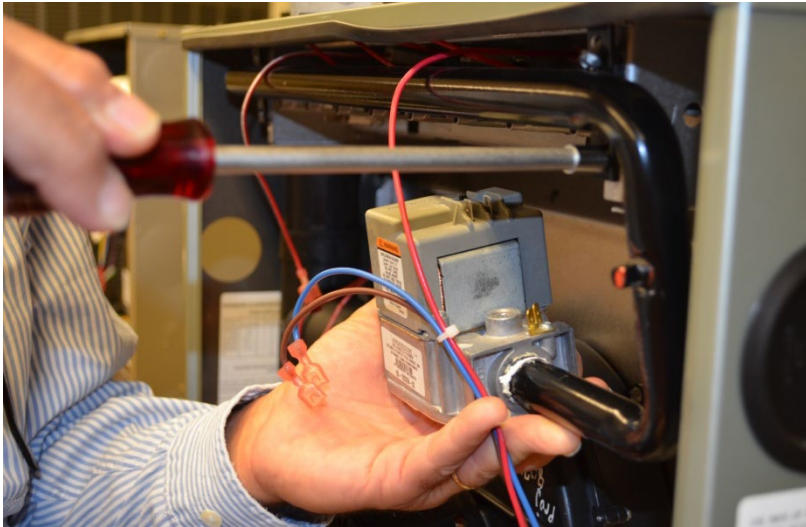

1. Remove manifold mounting screws

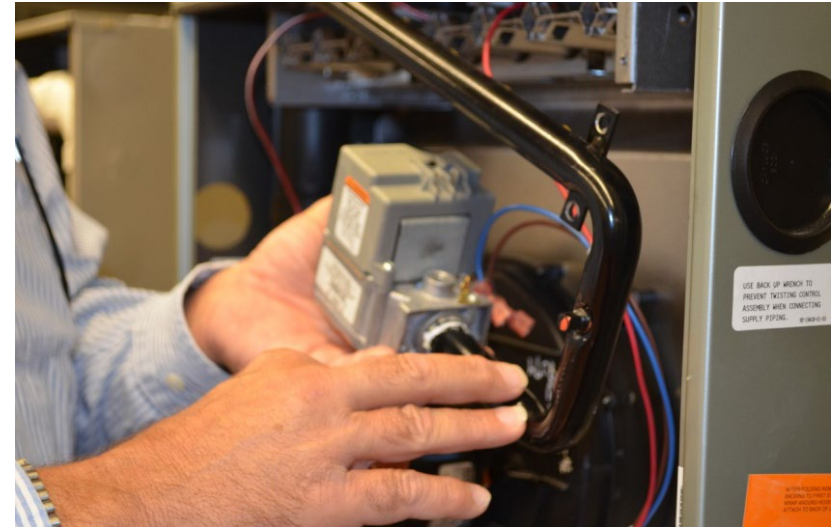

2. Remove gas valve from the manifold

Handle the manifold carefully so the spuds are not damaged, and the orifices maintain their proper size and shape.

Installing the Replacement Gas Valve

Mounting Orientation

- 36J and 36G valves are multi poise and can be installed in any orientation
- 36H must be mounted upright or up to 90° from upright

36H Mounting Positions:

Upright, or 0° to 90° from upright

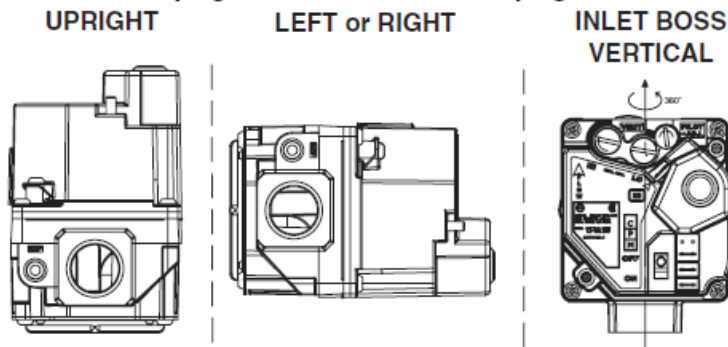

Gas Piping Requirements

- Drip legs must be installed upstream of the appliance at the lowest spot in the gas train
- Manual shutoff must be within six feet of the appliance

OEM Recommended Piping:

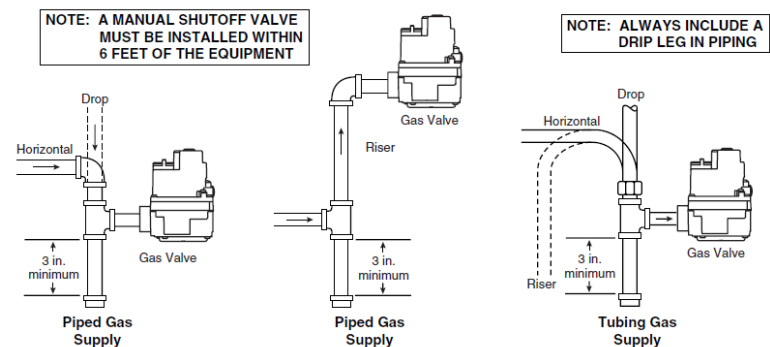

Flow Direction

36J

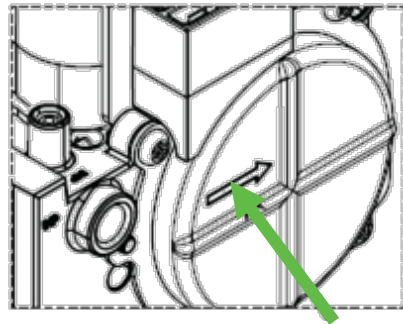
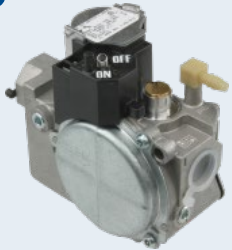

Gas flow
direction

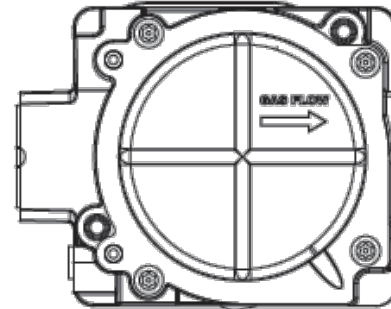

36H



- The arrow on the valve body indicates the required direction for gas flow
 - The arrow points from the supply inlet to the manifold outlet
- On the 36J and 36G models, the arrow is on the side
- On the 36H model, the arrow is on the bottom

Piping Connections

- Ensure the threads of the supply pipe are clean and free of rust, scale, burrs, chips, and old joint compound.
- Apply pipe joint compound (pipe dope) to the male threads only.
 - NOTE: Do not apply compound to the first two threads.

Inlet boss

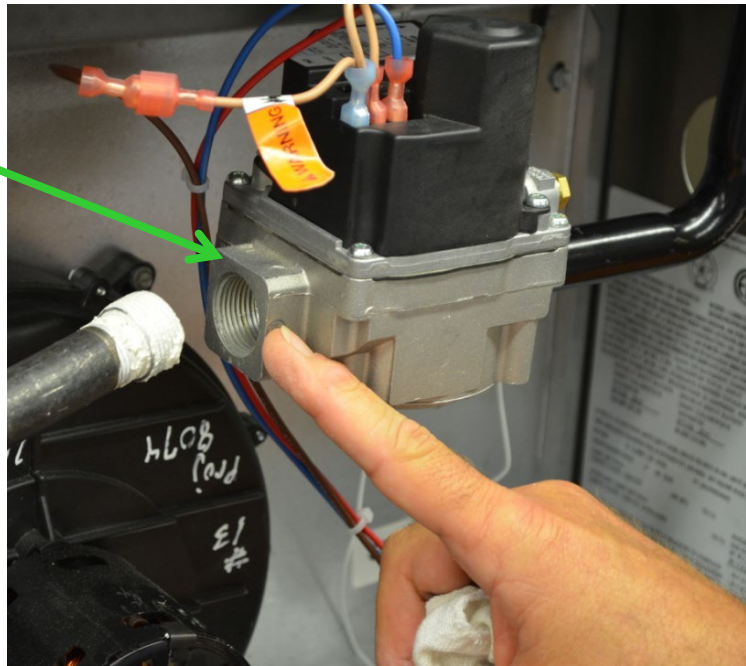

Installation Technique

Always use a back-up wrench when tightening to prevent the valve from rotating on the manifold connection.

Ensure the manifold piping does not move and misalign the burners or spuds—this can cause flame impingement.



Caution: the cast aluminum inlet boss can crack if too much torque is applied.

36H and 36G Pilot Tubing Installation

For furnaces with proven/intermittent pilot ignition:



1. Remove pilot plug

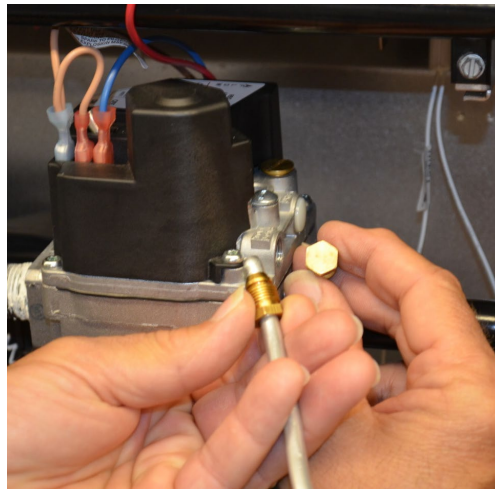

2. Install new pilot compression fitting

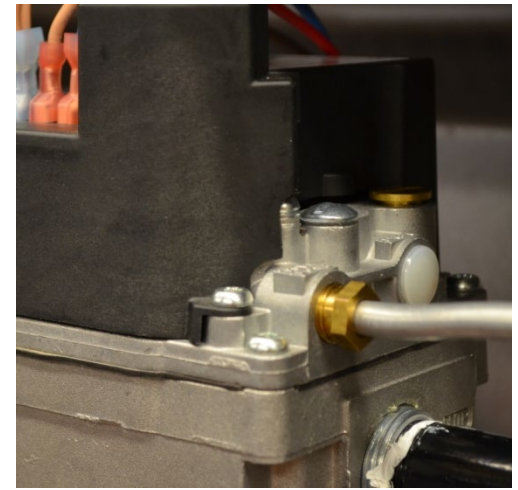

3. Tighten until the ferrule breaks loose, then a half turn more

Verifying and Setting the Gas Pressure

Check the system manufacturer's data plate for minimum/maximum supply pressure and recommended manifold pressure.

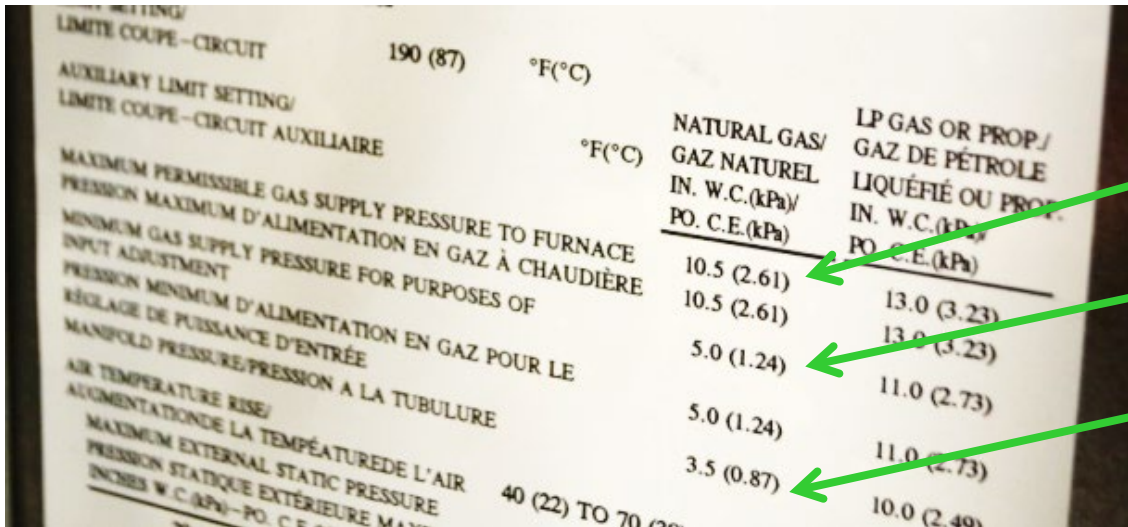

Maximum 10.5 " W.C.

Minimum 5.0 " W.C.

Manifold 3.5 " W.C.

Measuring Pressure in Inches of Water Column

- Low pressures are often measured in inches of water column or “W.C.”
 - In a water manometer, 1 inch of water column is literally the amount of force it takes to raise the column of water by 1 inch
 - While some water manometers are still in use, the vast majority are either dial or digital gauges that use the same scale
 - Water column gauges are calibrated at atmospheric pressure for the location

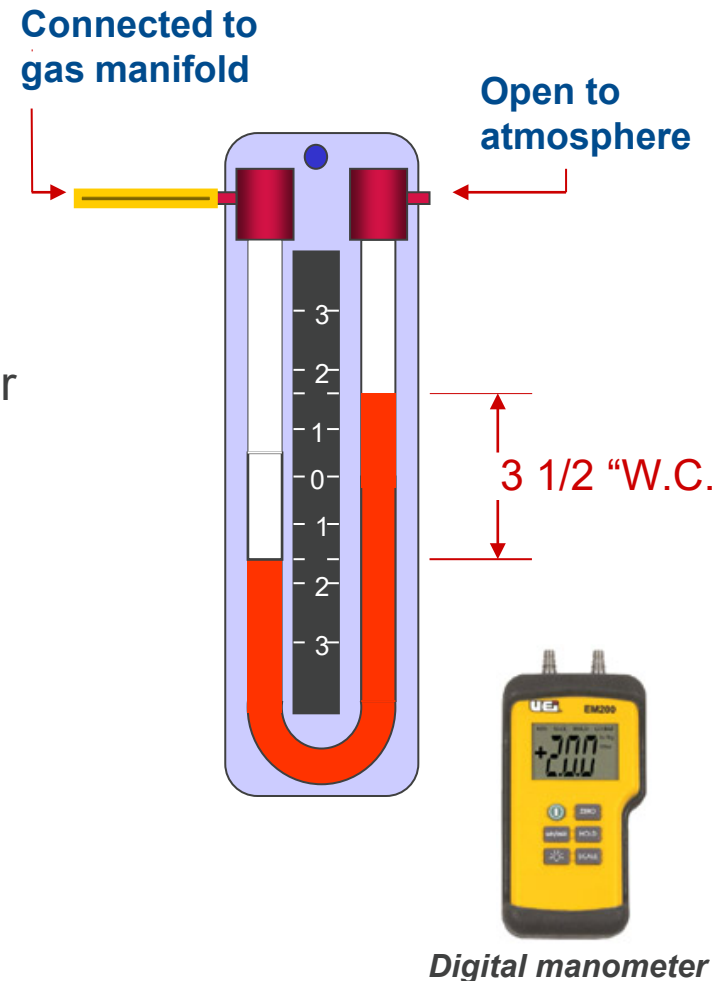

TECH TIP: For a manometer or magnehelic gauge to be properly used, they must be recalibrated to zero before each use to compensate for changes in elevation and barometric pressure.

Inlet Gas Pressure WC Settings

PSI to Inches of Water Column Conversion		
28" WC	Equals	1 PSI
14" WC	Equals	½ PSI
7" WC	Equals	¼ PSI

Operating Pressures	Max. Inlet Pressures "WC	Min. Inlet Pressures "WC
NG – Natural Gas	14"	5"
LPG - Liquid Petroleum	14"	11"

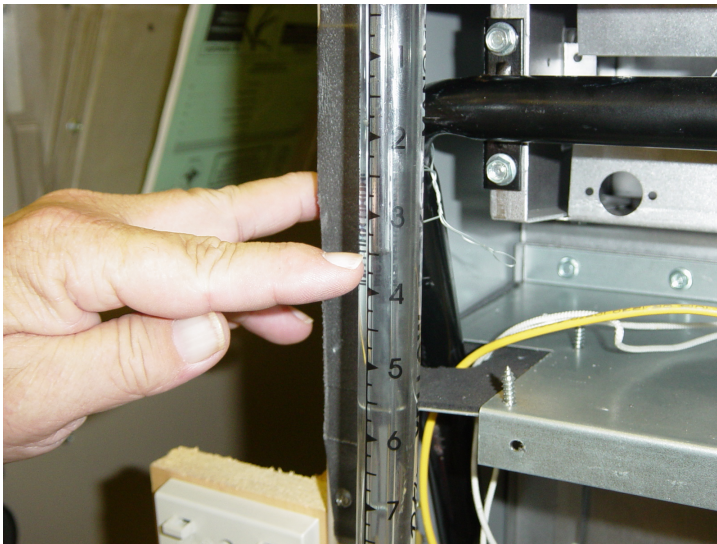

Water manometer with one-inch increments



Magnehelic gauge



Digital manometer

Locating Gas Pressure Taps

Two styles of pressure test ports:

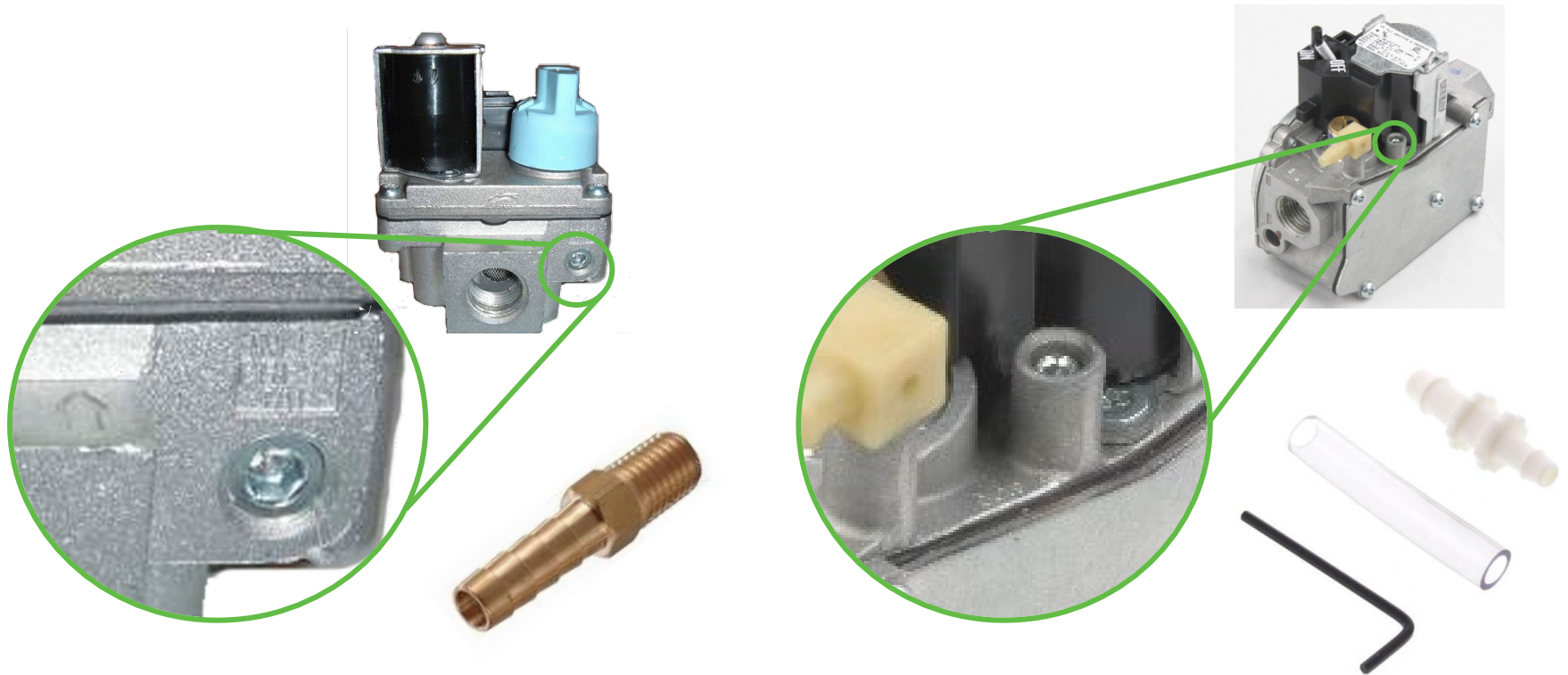

1. Removable plug for use with 1/8" MPT/barbed adaptor

2. Integrated tower-style pressure tap for use with 5/16" ID tubing adaptor

Locating Gas Pressure Taps

Locate the pressure test port for both the inlet (supply) pressure and the outlet (manifold) pressure.

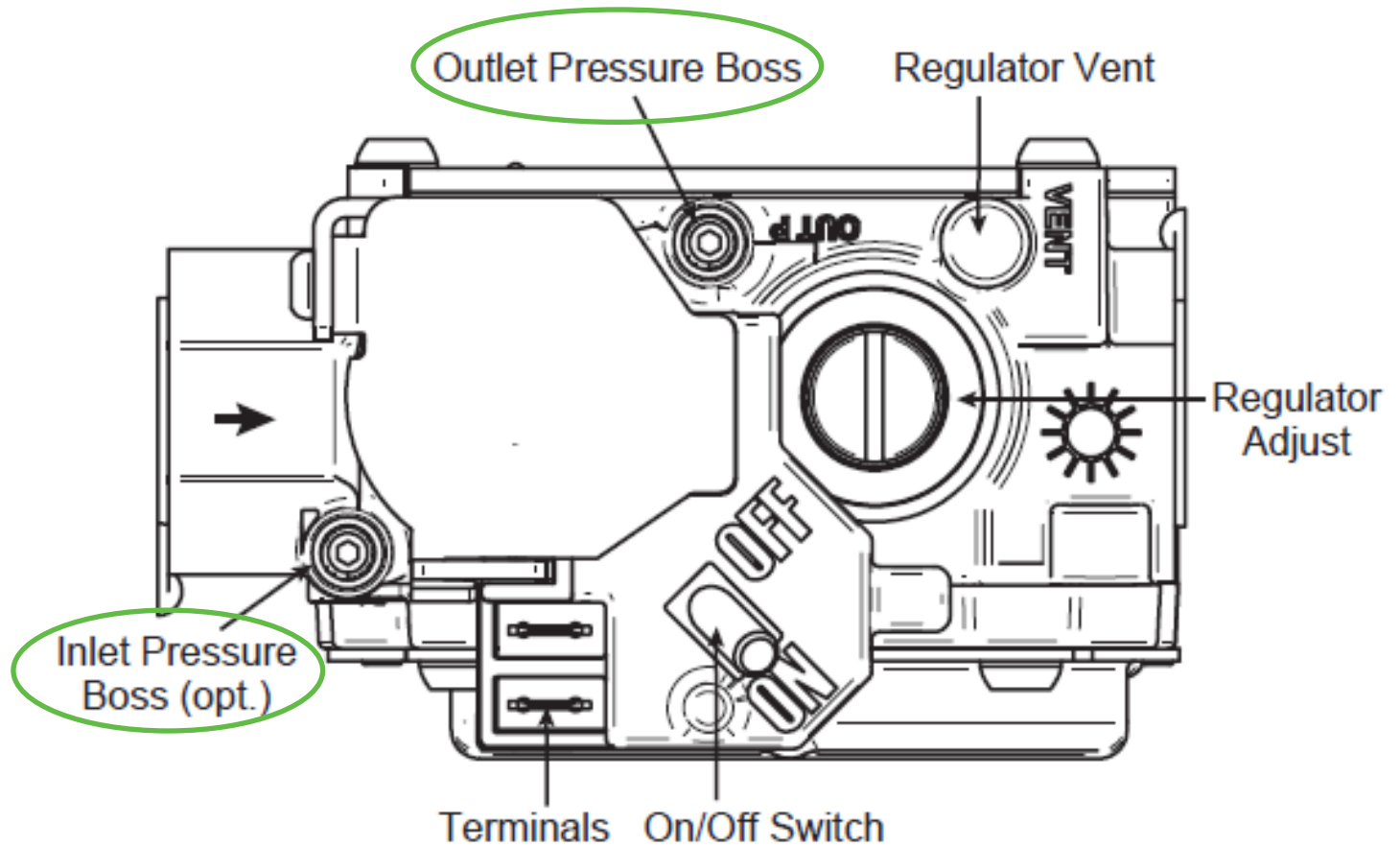

36J Inlet/Outlet Tower-style Pressure Tap

Insert a 3/32" hex key and open port by turning the screw one half rotation counterclockwise.

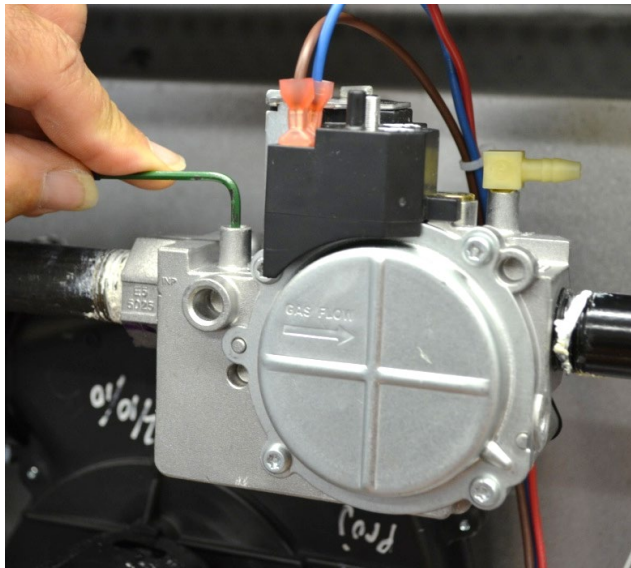

Inlet pressure tap

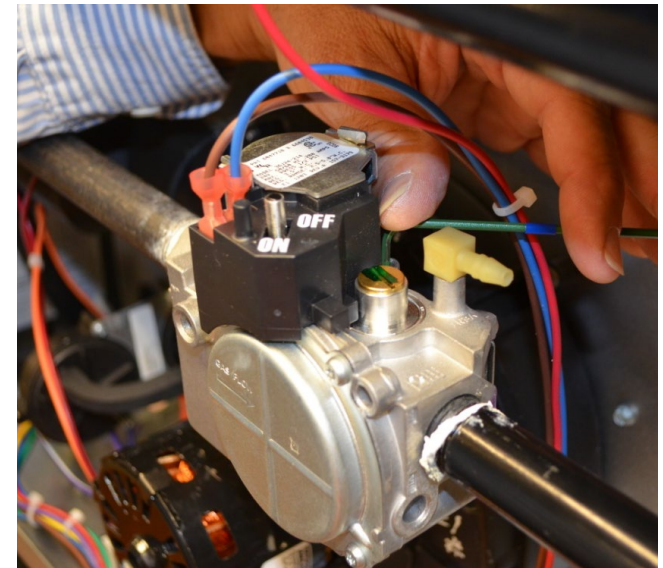
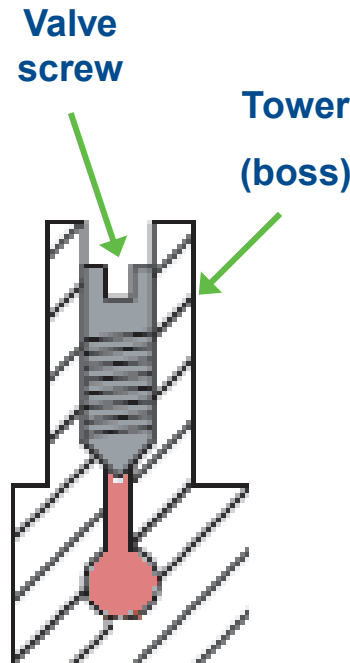

Outlet pressure tap

 **TECH TIP:** Ensure gas supply is shut off when opening pressure taps to connect manometer tubing.

Measuring Pressure

- Fit 5/16" ID tubing adaptor over pressure tap boss
- Gas pressure can only be accurately tested during a call for heat
 - Measuring inlet pressure without gas actively flowing through the valve is a dead-head reading that will not reveal any line pressure issues



Inlet (supply) pressure



Outlet (manifold) pressure

Plastic Barbed Fitting on the 36J

- A 90° plastic hose barb is found on some 36J controls
 - This is not an outlet pressure tap
 - Used on systems with sealed combustion chambers to vent gas and equalize regulator pressure
 - Connected to burner box with flexible tubing

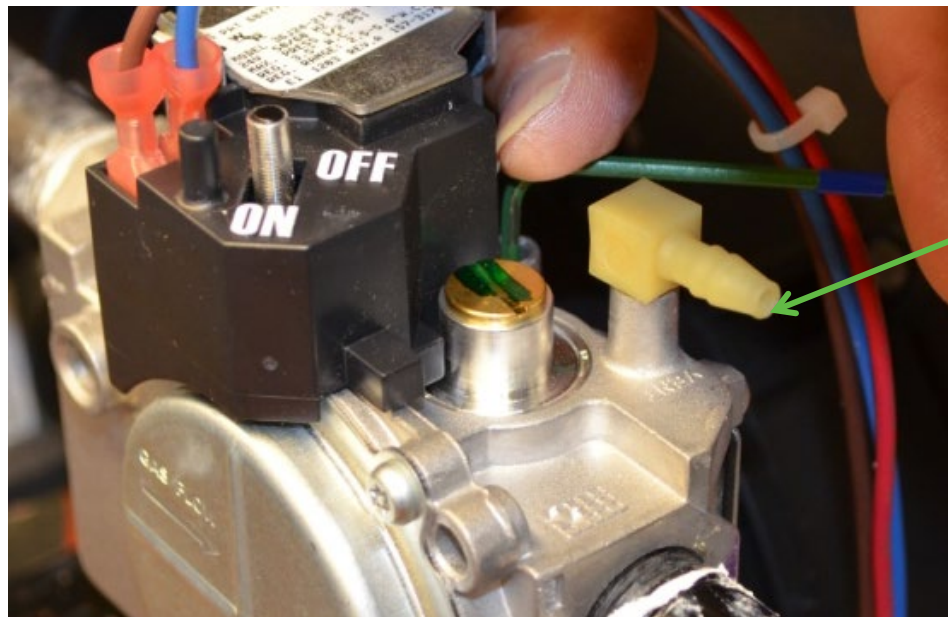

**Barbed vent fitting
not used for outlet
pressure**

Connecting 1/8" NPT Barbed Adaptor



1. Remove plug using 3/16" hex key



2. Insert MPT adaptor into threaded test port



3. Auxiliary port on manifold may be used (if present)

 **TECH TIP:** Ensure thread sealant is used on male plug fitting when reinstalled.

Adjusting Manifold Pressure

Remove cap to access the manifold adjustment screw.

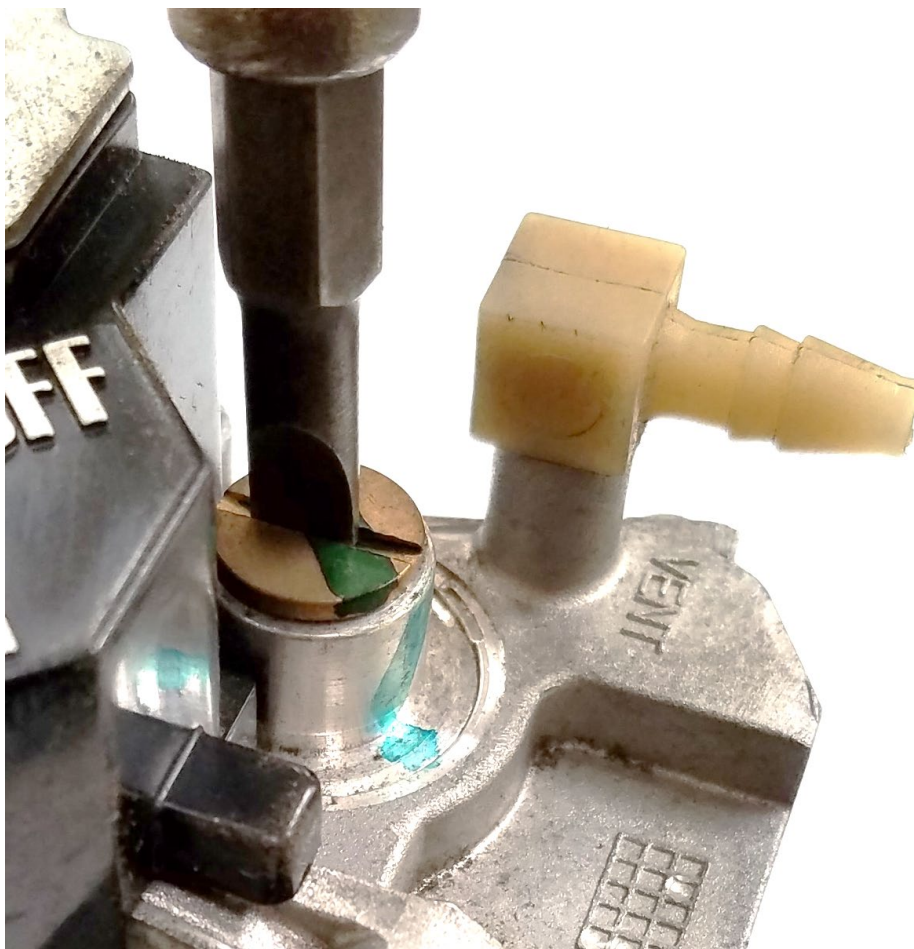

Adjusting Manifold Pressure

Use screwdriver to turn regulator adjustment screw.

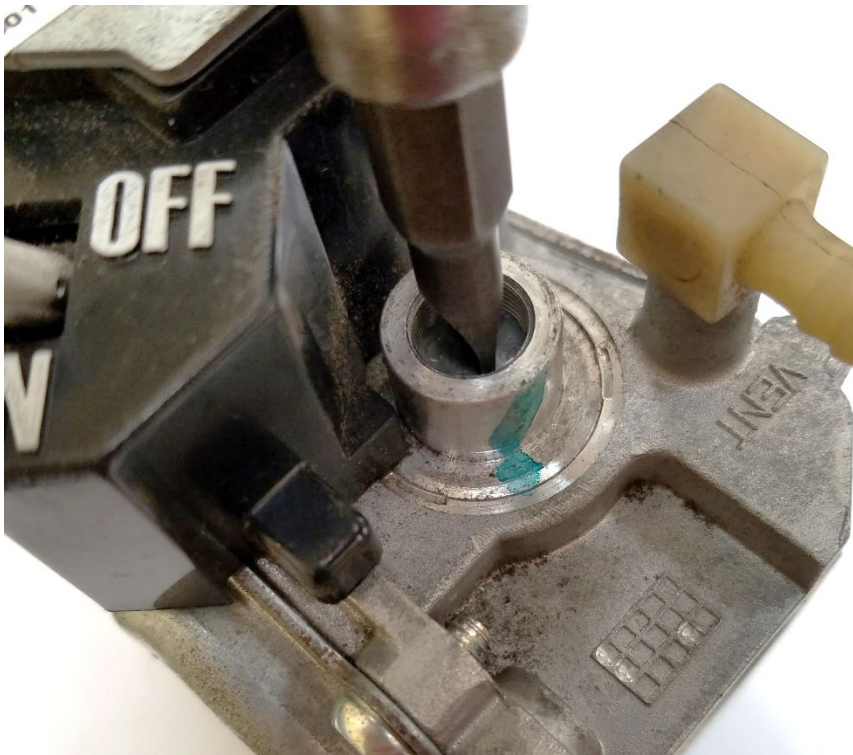

Clockwise increases outlet pressure



Counterclockwise decreases outlet pressure

 **TECH TIP:** Adjust in small increments: less than one quarter turn.

Adjusting Manifold Pressure on Two Stage Valve

- Check the data plate for manufacturer's recommended pressure settings
- Adjust high fire first
- Adjust low fire second

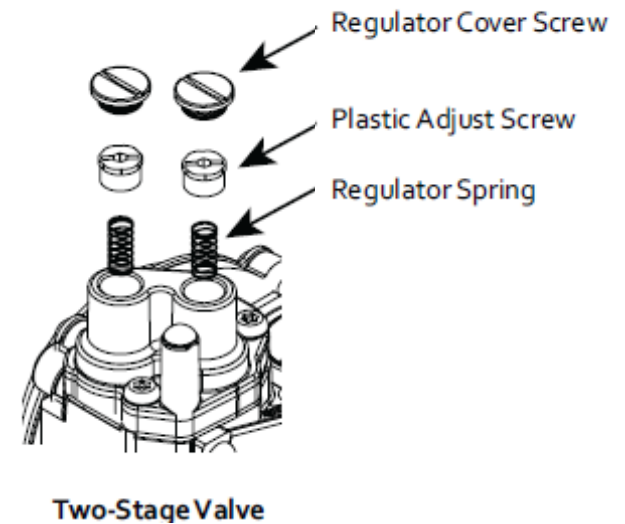

TECH TIP: After adjusting both high and low fire, go back and check/fine tune pressures.

Adjusting Regulator and Pilot on the 36H/36G

Pilot and manifold pressures are adjusted independently.

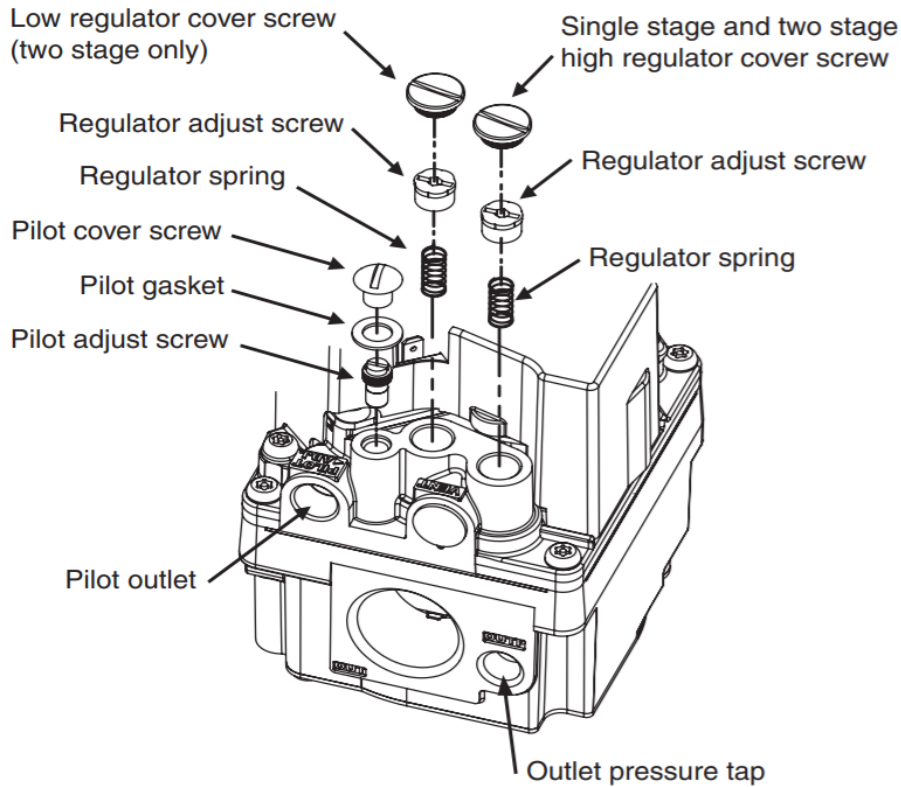

Pilot adjust

Manifold adjust

TECH TIP: The pilot adjust screw must be turned in the opposite direction to adjust the pressure, clockwise reduces and counterclockwise increases.

Converting from Natural Gas to LP

- Remove regulator cover screw
- Remove plastic adjust screw
- Extract regulator spring for natural gas
- Replace spring with LP spring from conversion kit
- Replace plastic adjust screw and set manifold pressure

ACCESSORIES		
Regulator Conversion Kits		
F92-0659	Natural Gas to LP	Single Stage
F92-0737	Natural Gas to Unregulated LP	Single Stage
F92-1008	Natural Gas to LP	Two Stage
F92-0656	LP to Natural Gas	Single Stage
F92-1011	LP to Natural Gas	Two Stage
F27-0373	Flange Mount Kit	Single or Two Stage

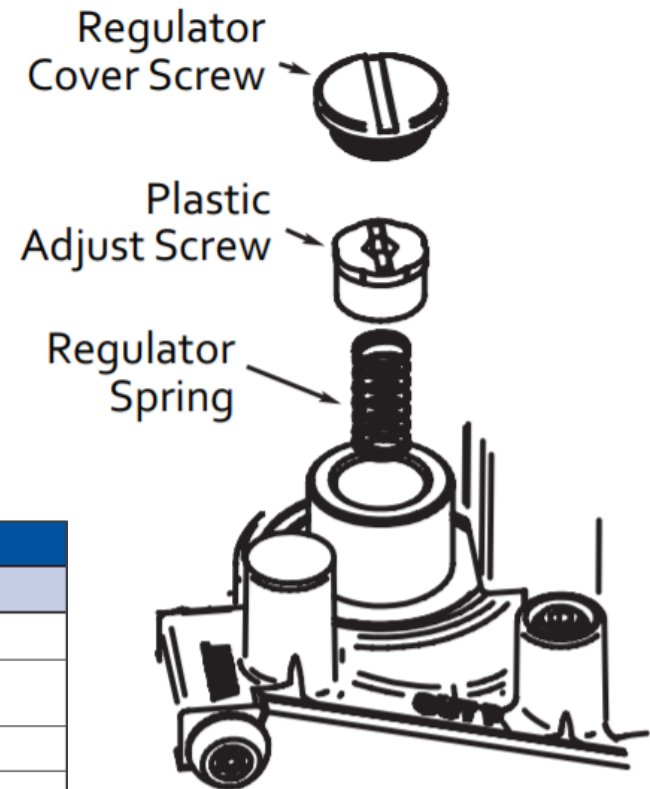

Single Stage Valve

TECH TIP: Check with furnace manufacturer to ensure proper orifice size requirements for liquefied petroleum gas.

Key Takeaways

- Replacement gas valves must be installed carefully and in the proper orientation
- For a system to operate properly, the inlet (supply) pressure must be within the minimum and maximum range as set out by the manufacturer
- After installation, the outlet (manifold) pressure must be confirmed and/or adjusted by a technician

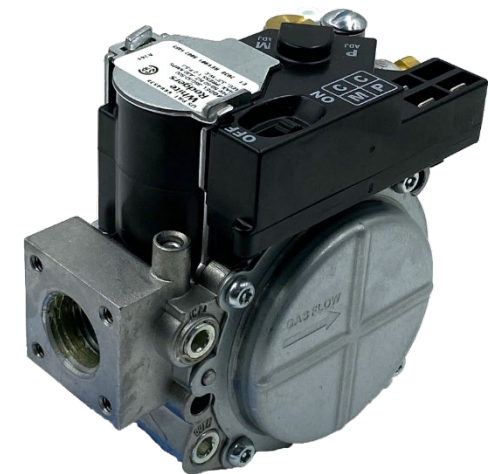

White-Rodgers Cross Reference

Go to: www.whiterodgers.com

- Hover over Tools & Resources
- Click on: White-Rodgers Cross Reference/Product Information
- Enter the Model Number or click on: Search Replacement Heating Controls by Major OEM Brand

The screenshot shows the Emerson website header with navigation links: Emerson.com, About Us, Investors, Careers, Contact Us, News & Events, Sign In, and United States (English). Below the header is the 'CLIMATE TECHNOLOGIES' section with sub-links: Products, Industries, Training & Support, Tools & Resources (highlighted), and Expertise. A search bar and shopping cart icon are on the right. The main content area features a large image with the text 'Transforming How People and Work' and a sub-headline 'Drawing on our expertise and global perspective, we combine technology to develop HVACR and infrastructure solutions for our customers.' A white dropdown menu is open over the 'Tools & Resources' link, listing various resources. A green arrow points to the link 'White-Rodgers Cross Reference/Product Information' within this menu.

Emerson.com About Us Investors Careers Contact Us News & Events Sign In United States (English)

EMERSON CLIMATE TECHNOLOGIES

Products Industries Training & Support **Tools & Resources** Expertise

Search

Transforming How People and Work

Drawing on our expertise and global perspective, we combine technology to develop HVACR and infrastructure solutions for our customers.

TOOLS & RESOURCES

- Air Conditioning Webinars
- Application Engineering Knowledge Center
- Copeland Online Product Information
- E360
- Ebooks
- HVAC On Air Podcasts
- HVACR Calculators
- Mobile Apps
- The Helix
- Where To Buy
- [White-Rodgers Cross Reference/Product Information](#)
- Product Selection Software

Troubleshooting and Servicing Gas Valves

When to Replace a Gas Valve

- If there is no heat and:
 - *There is a valid call for heat from the thermostat*
 - There is no clicking sound when the valve is energized
 - There is no measurable pressure at the outlet
- If the system efficiency is down and:
 - Other causes have been ruled out
 - If the outlet pressure remains above the set point or fluctuates, it is not operating properly
 - The manifold regulation should stabilize after about 20 seconds and stay within +/- 10% of the set pressure setting
- If the gas valve has been subjected to water flooding
- If the manifold pressure cannot be adjusted



Troubleshooting Gas Valves - Electrical

- When the solenoid coil is energized, the redundant and main valves are drawn open.
- When the coil is deenergized, the return spring closes the valves.
- When the coil is energized, 24V can be measured between the two terminals.
- If 24V is present at the solenoid and there is inlet pressure but no outlet pressure, the valve has failed to open.
- A stuck plunger (seized solenoid) will cause an increase in current that can cause the low voltage fuse to blow.
- A grounded solenoid coil (wire from coil touching valve body) will cause an overcurrent and blow the low voltage fuse

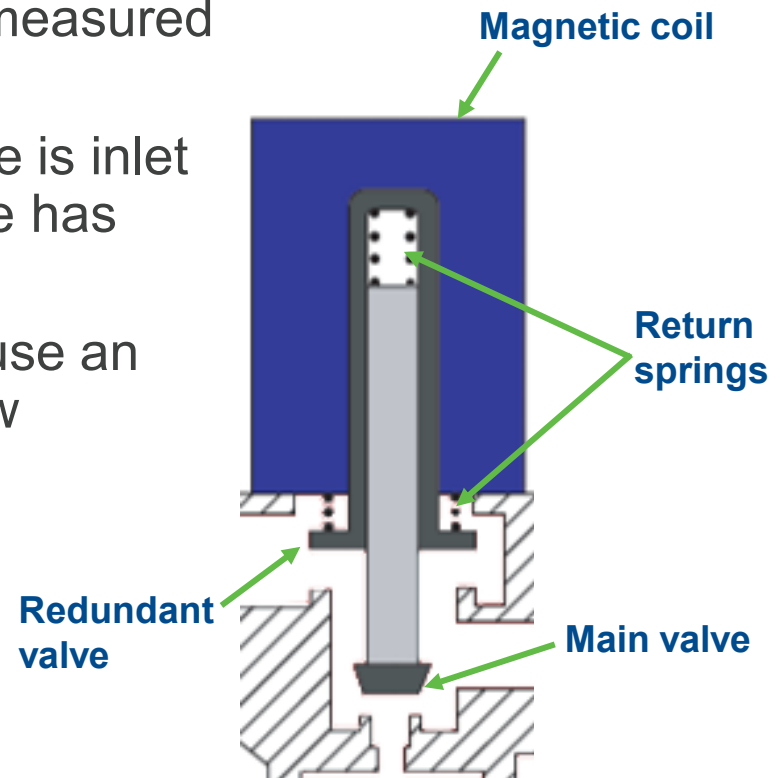

Troubleshooting Gas Valves - Mechanical

- High outlet pressure
 - Regulator set too high
 - Can increase overall system temperature rise and outlet temperatures
 - Can cause burner liftoff/noise and flame impingement
 - Can overheat/perforate heat exchanger
 - Can permanently damage the diaphragm
 - Results from dirty or clogged internal bypass channels in regulator body
 - Corrosion and contamination due to excessive moisture or flooding
 - Can result in slowing the closing action of the valve as well

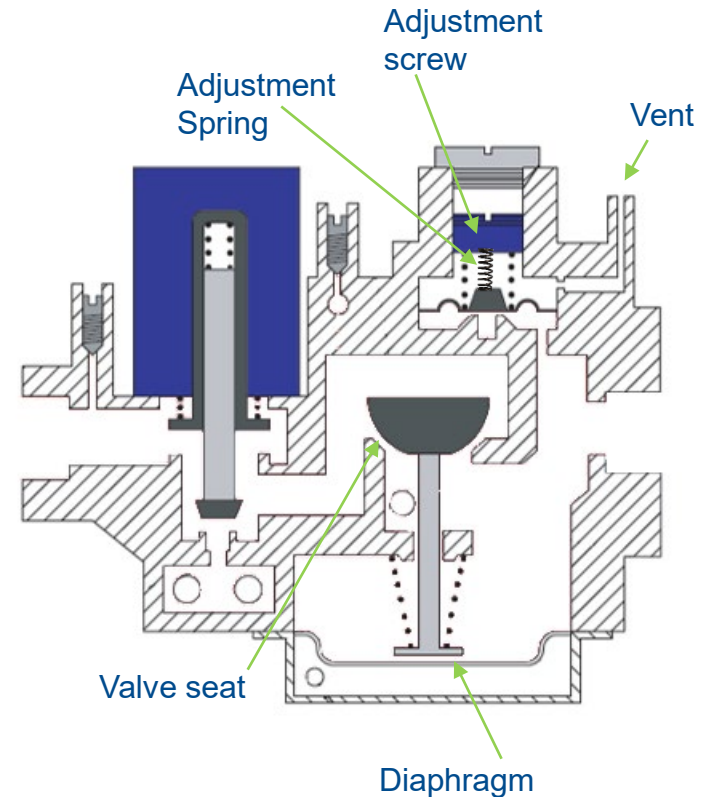

TECH TIP: Visually inspecting the main burner flame cannot accurately determine if the pressures are within the manufacturer's specifications.

Troubleshooting In-line Gas Regulators

- The regulator spring is designed to maintain a set pressure regardless of upstream fluctuation.
- As the supply pressure increases, it puts back-pressure on the diaphragm and spring, forcing the valve to close.

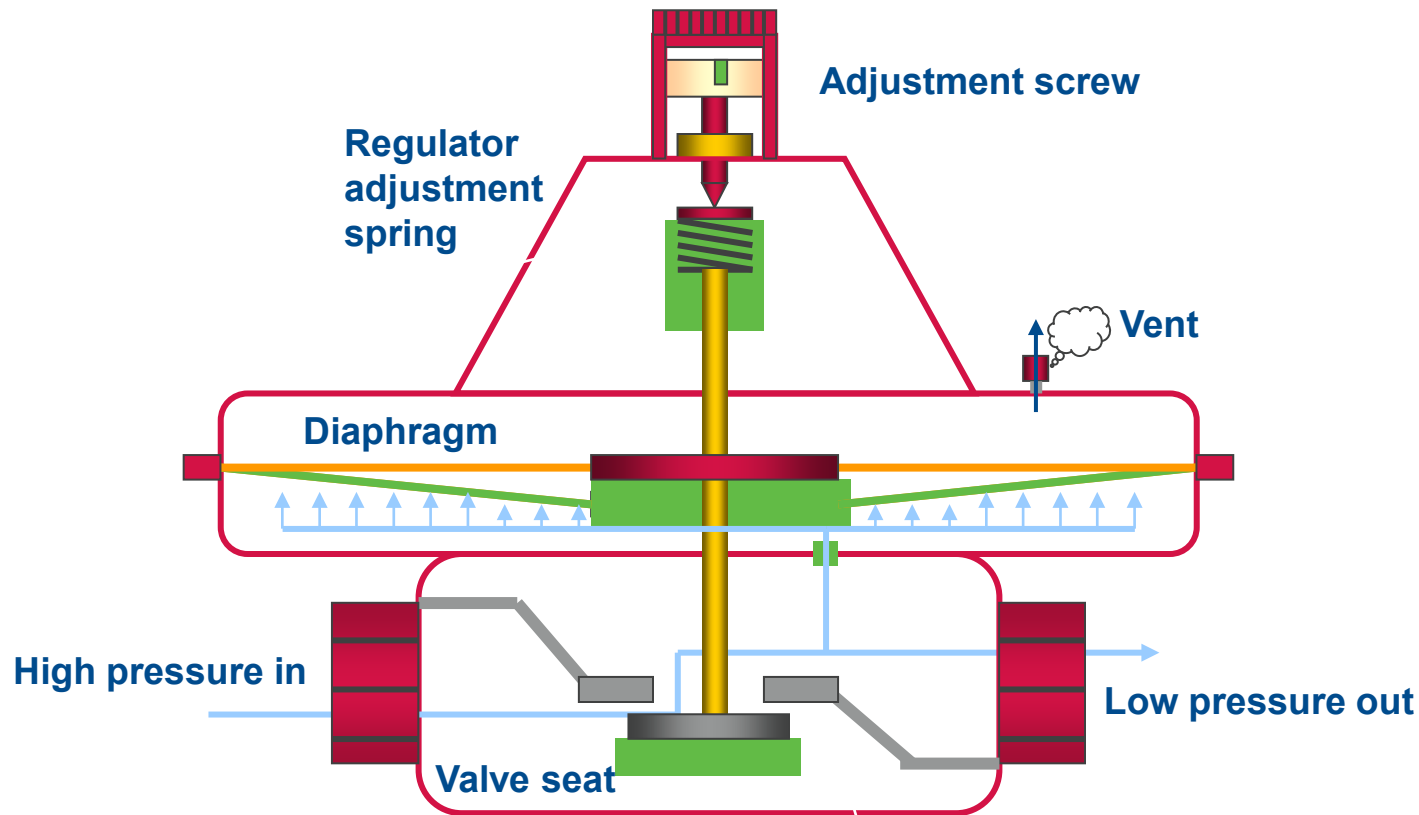

Troubleshooting In-line Gas Regulators

- The internal diaphragm must flex to effectively regulate the pressure.
- Pressure buildup on back side of the diaphragm will cause an increased outlet pressure.
- Excessive back-pressure must be vented to atmosphere to maintain proper flexibility and pressure regulation.

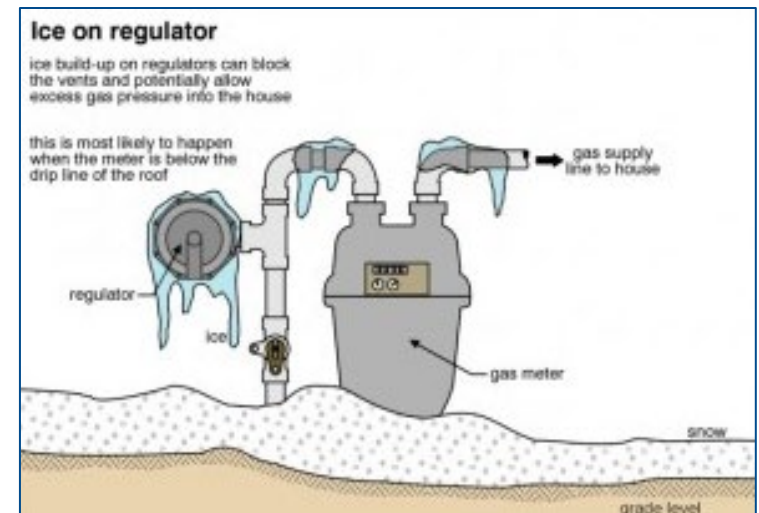
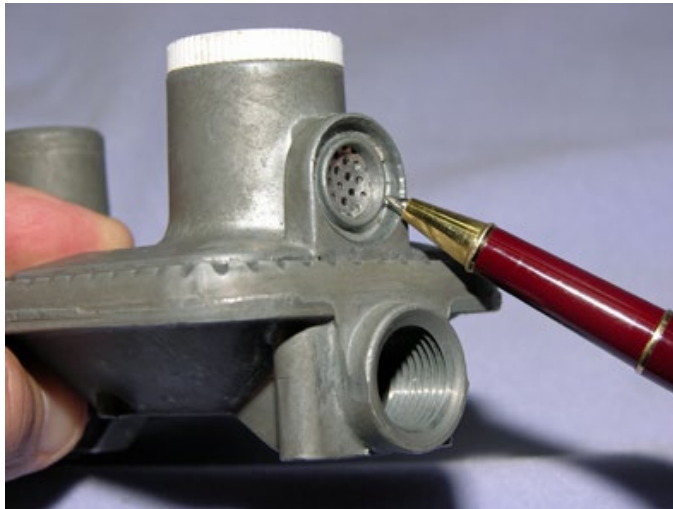

 **TECH TIP:** Ice buildup on the outdoor regulator can prevent venting and cause increased gas pressure entering house.

Results of Gas Valve Contamination

Corrosion or contamination in either orifice will greatly affect the outlet pressure.

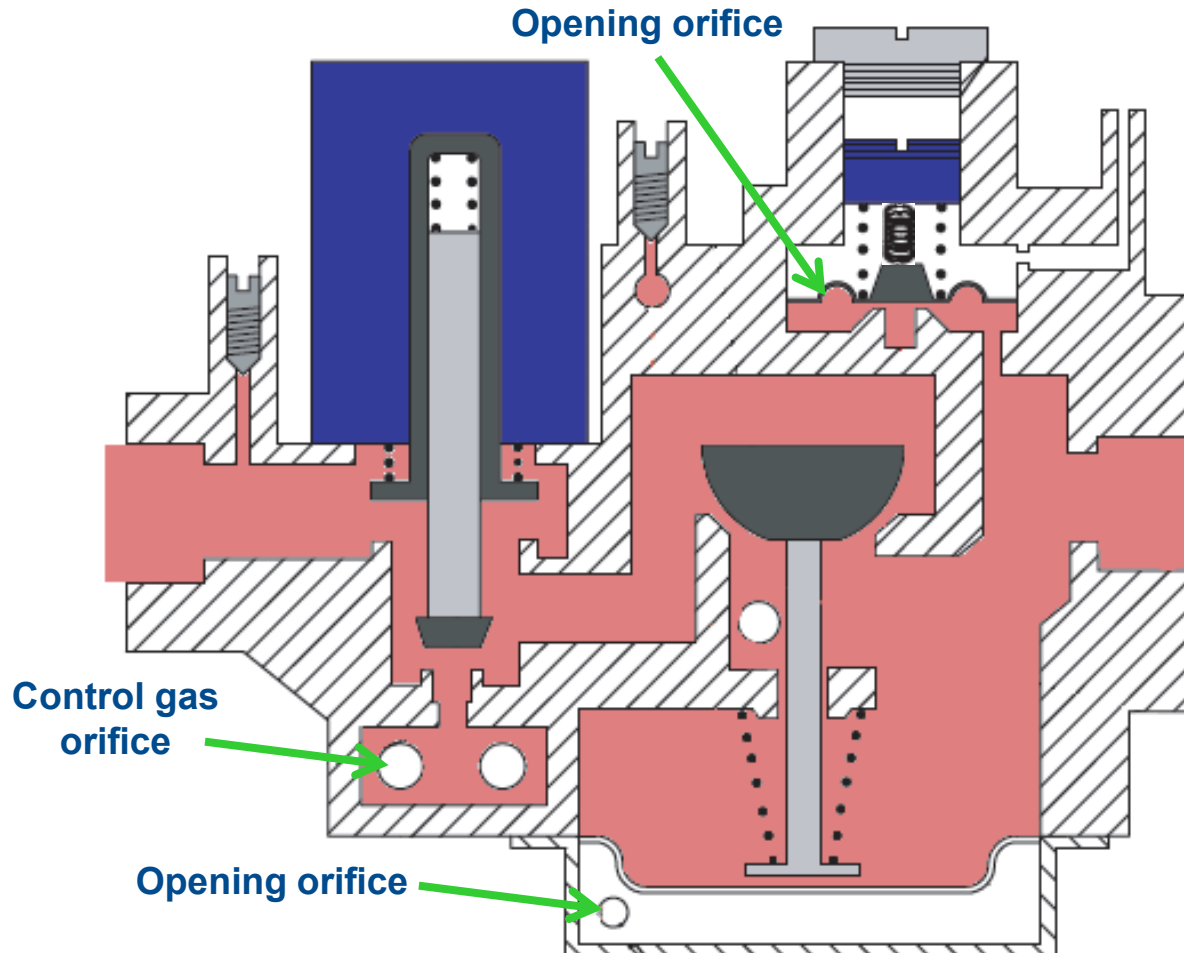

Key Takeaways

- Before condemning a gas valve, verify the presence of the control voltage and supply gas pressure
- If a gas valve has been exposed to excessive moisture or has been submerged in a flood, it must be replaced
- Improperly adjusted gas valves can damage the heat exchanger
- Failed gas valves are not field serviceable and must be replaced

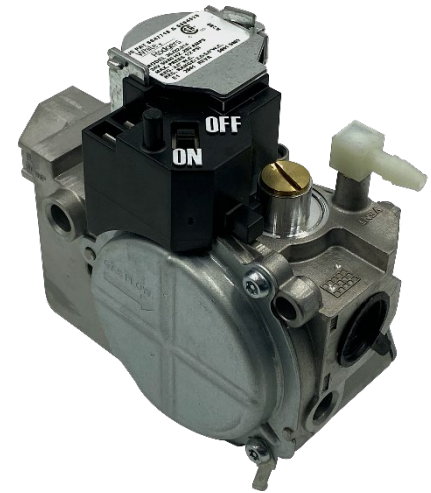

Why Contractors Trust White-Rodgers

Industry Leading Products

- Used by more OEM's
- Offering the widest range of Universal Replacement Controls

Ease of Installation

- Simple, easy to understand instructions

Product Reliability

- Quality Control assures reliable products

Affordable

- Competitive pricing

Supported by Knowledgeable Representatives

- Contractor direct phone support



Wholesale Resource Site

Access useful resources to grow your business.

Visit: <https://climate.emerson.com/en-us/brands/white-rodgers/white-rodgers-wholesaler-resource-center>

You'll find videos, stocking lists and product launch information for the following product families:

- Heating Controls
- Cooling Controls
- Sensi Smart™ Thermostats
- Traditional Thermostats
- Contractor Rewards
- Product Merchandising

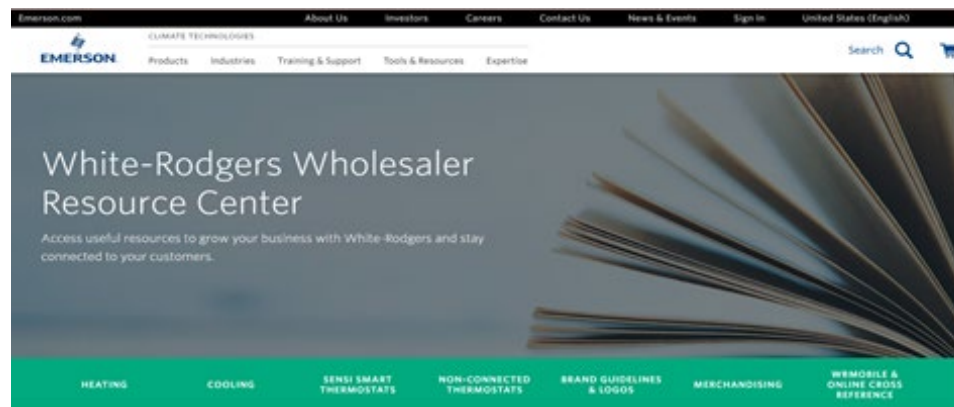

The comfort in knowing Emerson is there.

Confidence comes from knowing your reputation is in good hands; that you have the stability of an industry leader by your side; that they've been in the game for 125 years and they'll be around for a whole lot longer. That's the comfort you feel when you recommend Emerson, because you know you're working with the best for your customers and your business.

[BROCHURE](#)